



12843 Foothill Blvd.,
Suite D
Sylmar, CA 91342
818 898 3380 voice
818 898 3360 fax
www.dnfcontrols.com

Model No. 2034CL-MAV-PBIO (&2034CL-MAV-T-PBIO)

**300 CLIP INSTANT ACCESS SYSTEM
with Peripheral Bus Interface Option**

Sony DP Protocol

for SONY MAV-555 Video Servers

NOTE: Supports up to 3 Video Server Channels

USER MANUAL

TABLE OF CONTENTS

1.	REVISION HISTORY	4
<i>GETTING STARTED...</i>		5
2.	SYSTEM DESCRIPTION	5
	DEFINITIONS	5
3.	SYSTEM INSTALLATION	6
	a. SHOTBOX	6
	b. ST300-S/SM, VTR/DDR CONTROLLER	6
	c. PRODUCTION SWITCHER	6
4.	VIDEO SERVER SETUP	8
5.	LOAD AND LEARN EXISTING CLIPS	8
6.	LEARN	8
	a. LEARN ON THE ST300	8
	b. LEARN ON THE SHOTBOX	9
	c. LEARN ON THE PRODUCTION SWITCHER	9
7.	RECALL	9
	a. RECALL on the ST300	9
	b. RECALL ON THE SHOTBOX	9
	c. RECALL ON THE PRODUCTION SWITCHER	9
8.	TRIGGER	10
<i>ADVANCED FEATURES...</i>		11
9.	SET RECORD DURATION	11
10.	CREATE NEW CLIPS	11
11.	SETTING THE IN (OUT) POINT	12
	a. MARKING THE IN (OUT) POINT	12
	b. VIEW THE IN (OUT) POINT	12
	c. CLEARING AN IN (OUT) POINT	12
12.	ENTER PREROLL VALUE	12
13.	TRIMMING CLIPS	13
14.	LOOPING A CLIP	13
15.	VIEW CONTENT OF CUE POINTS	13
16.	SHOTBOX SHOTKEY MAPPING TO SHOTLIST LOCATIONS	14
17.	SHOTBOX CONTROL SWITCHES	14
18.	PBIO TO CUE POINT MAPPING	14
19.	TRANSFERRING CUELIST	15
	a. TRANSMIT CUELIST FUNCTION	15
	b. RECEIVE CUELIST FUNCTION.	16

REFERENCE... **17**

20.	SETUP MENU	17
21.	FUNCTION TABLE	19
22.	SPECIFICATIONS	20
	ST300	20
	ST420 (SHOTBOX)	21
23.	TROUBLESHOOTING	22
	ST420 TROUBLESHOOTING	22
24.	DNF CONTROLS LIMITED WARRANTY	23

Manual Version.....2.7 020504
Document No.....2034CL-MAV-PBIO User Manual

1. REVISION HISTORY

092203	Rev. 2.4	Company header information revised.
110403	Rev. 2.5	Added DNF Controls Limited Warranty. Updated Receive Cue List & Transmit Cue List Function description.
121003	Rev. 2.6	Reformatted. Revised TRIMMING CLIPS Section Added Video Sync, Video Standard, Recall Menu Options.
020504	Rev. 2.7	Added note to cover and System Description: Supports up to 3 Video Server Channels.

Getting Started . . .

2. SYSTEM DESCRIPTION

The 300 Clip Instant Access System consists of the ST300-SSM VTR Controller and Shotlist Software. The Video Server must support SONY DP Protocol.

The ST300 controls up to 3 video channels individually or ganged.

SHOTLIST provides instant access to existing video clips stored on SONY-MAV. The SHOTLIST contains up to 300 CLIP IDs, stored in non-volatile memory in the ST300.

Any clip in the SHOTLIST can be quickly loaded by simply entering the associated 3-digit number of its location, then pressing [**LOAD**]. Press [**PLAY**] to play the clip. Press [**RECUE**] to recue to the beginning of the clip or to the “recalled” time if defined.

Upon receipt of the Learn command, the ST300 saves the CLIP IDs of the currently loaded clips, the current IN time of each clip, the VTRs they are loaded on and the current GANG mode into the appropriate Cue Point.

When the Recall command is received, the ST300 loads the learned Clips onto the learned VTRs, cues the Clips to the learned time and restores the learned GANG mode.

DEFINITIONS

- ❑ Throughout this document, the MAV-555 will be referred to as “Video Server.”
- ❑ The ST300-S/SM as the ST300.
- ❑ The ST420 is referred to as the SHOTBOX.
- ❑ Words surrounded by brackets, for example, [**ENTER**], are keys on the ST300 or the SHOTBOX. [**XXX**] + [**XXX**] means hold the two keys down simultaneously.
- ❑ “Softkeys” are the row of keys directly below the display that perform multiple functions in MENU and other modes.

3. SYSTEM INSTALLATION

a. SHOTBOX

- 1) Plug one end of a standard 9-pin, RS422 serial cable, into the OUTPUT connector on the rear of the SHOTBOX. Plug the other end of the cable into the AUX connector on the rear of the ST300.
- 2) Connect the 5 VDC, 1Amp POWER SUPPLY into the POWER connector on the rear of the SHOTBOX. Plug the Power Supply into an outlet, 90 VAC – 240 VAC.

b. ST300-S/SM, VTR/DDR CONTROLLER

- 1) Plug one end of a 9-conductor, RS422 serial cable into the VTR1 (2 or 3) connector on the rear of the ST300. Plug the other end of the cable into the REMOTE connector on the Video Server.
- 2) Connect the +5, +12, -12 VDC POWER SUPPLY into the POWER connector on the rear of the ST300. Plug the Power Supply into an outlet, 90 VAC – 240 VAC.
- 3) Check SETUP MENU prior to using the ST300 to confirm proper Record mode and other User preference modes.

c. PRODUCTION SWITCHER

- 1) Connect a standard cable (RS422, 9-pin serial cable) to the supplied turnaround adapter. Plug the turnaround adapter into the “VTR4” connector on the rear of the ST300. Connect the other end of the cable to the Peripheral Bus Connector on the production switcher. (Communication Format- 38.4K, N, 8,1)
- 2) The ST300 has 3 Peripheral Device Addresses, one for each VTR that it controls. To set the Device Address for each VTR:
Press [MENU] and turn the Wheel until “Peripheral Address” is displayed.
- 3) Press VTR[1], VTR[2] or VTR[3] to select a VTR.
- 4) Assign a Peripheral Device Address for that VTR, from 0 to 23, by using the numeric keypad. Address 24 or greater will turn PBIO off.
- 5) Select the next VTR, and then assign a Peripheral Device Address for it.
- 6) To select a Production Switcher type (Default = Grass Valley Group).
 - a) Press [MENU] and turn the Wheel until “SWITCHER” is displayed.
 - b) Press the Softkeys to toggle between Sony and Grass Valley.
 - c) For version 3.0 hardware, you will have the option to set Parity to match the parity of the production switcher. In hardware versions 2.0 and 2.1 you are not offered this option because the hardware automatically adjusts for the parity the switcher is set to.

- 7) When done, press [ESC] to exit the MENU.
- 8) Configure the production switcher:
 - Enable the Peripheral Bus.
 - Enable the Peripheral Device Addresses assigned to the ST300.
 - Enable the appropriate Learn/Recall levels.
 - Enable the Timeline or Recall Trigger function.

Installation is complete.

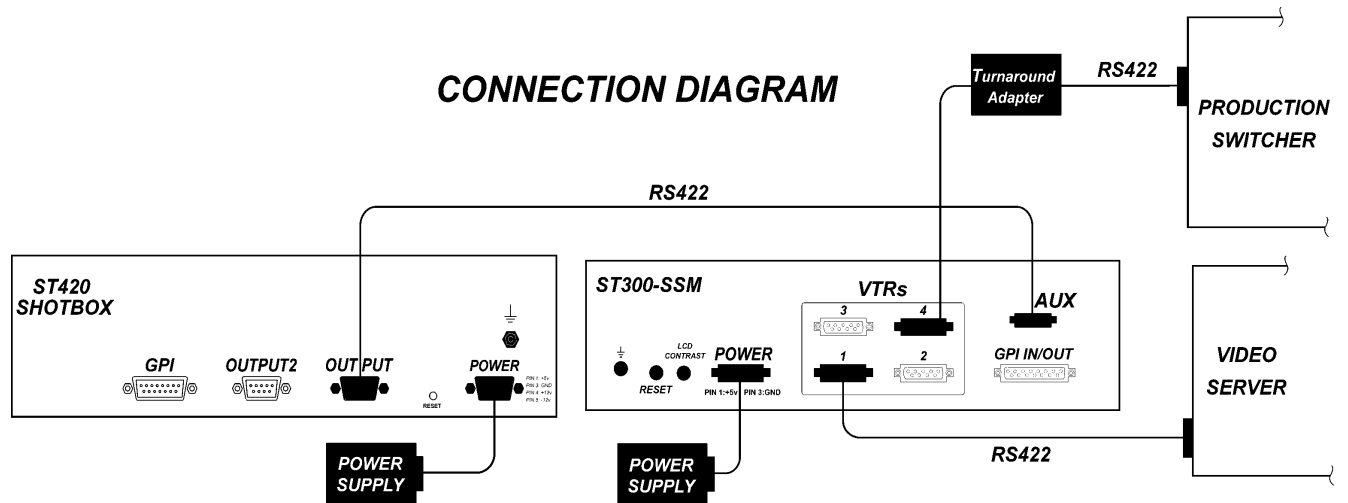

4. VIDEO SERVER SETUP

- a. The SONY MAV unit must have the following or higher software versions: V1.1
- b. Clips loaded from the front panel of the MAV will not be Learned or displayed on the ST300 or the SHOTBOX.
- c. SETUP MENU/RECORD MODE. Crash and Lockout are the only modes supported.

5. LOAD AND LEARN EXISTING CLIPS

- a. Select VTR. Connection must be to the Player port to load existing clips.
- b. Press **[CLIP LIST]**. The CLIP LIST indicator will turn on.
The display prompts: "WHEEL-scroll files, ENTER- enter file ID"
- c. Turn the Wheel.
The top line of the display will show "CLIP ID."
The bottom line of the display will show "xxxxxxxxxxxxxxxxxxxxxx:".
Where "xxxxxxxxxxxxxxxxxxxxxx" is the 20 character CLIP ID. (CLIP IDs can contain up to 24 characters. The ST300 is capable of displaying a maximum of 20 characters. If a CLIP ID has more than 19 characters, the last character is a "→".)
- d. Turn the Wheel to scroll through the list of available CLIPs.
OR
Type in an alphabetical ID using the "qwerty" keyboard on the SHOTBOX.
OR
Enter a numeric file ID using the numeric keypad on the ST300.
- e. Press **[LOAD]** to load the desired clip.
- f. Locate the clip to the desired IN time.
- g. Press **[ESC]** at anytime to exit CLIP LIST.

6. LEARN

a. LEARN ON THE ST300

- 1) LOAD a clip on the ST300 as described above.
- 2) Set IN and OUT points if desired.
- 3) Select the desired Cue Point by pressing **[NEXT CUE]**, **[LAST CUE]** or by manually entering the Cue Point using the numeric keypad.

The selected Cue Point number is shown on the bottom line of the display.

- 4) Press **[SHIFT]** + **[MARK]** to initiate the LEARN.

The display will show:

Press VTR: MARK-Lrn ESC-Cancel
--

- 5) Press the VTR key desired: **[1],[2],[3]**.
- 6) Press **[MARK]** and the ST300 will: LEARN (save) the VTR Number (1,2,3), loaded CLIP ID and current IN time to the selected Cue Point.

b. LEARN ON THE SHOTBOX

- 1) Press **[LEARN]**. The LEARN indicator will turn on.
- 2) Select the desired BANK and ShotKey.
- 3) Press **[LEARN]** to exit at anytime.
NOTE: The **[LEARN]** key toggles LEARN mode on/off.

c. LEARN ON THE PRODUCTION SWITCHER

- 1) Select and enable the Peripheral Device Addresses for the ST300.
- 2) Do a LEARN to the desired REGISTER.
The ST300 will save the VTR number, loaded CLIP ID and current IN time into the REGISTER number in the ST300.

7. RECALL

a. RECALL on the ST300

- 1) Select the desired Cue Point by pressing **[NEXT CUE]**, **[LAST CUE]**, or by manually entering the Cue Point using the numeric keypad.

The selected Cue Point number is shown on the bottom line of the display.

- 2) Press **[LOAD]** on the ST300.

b. RECALL ON THE SHOTBOX

Select the desired Cue Point by pressing the bank and the switch key.

c. RECALL ON THE PRODUCTION SWITCHER

- 1) RECALL the desired REGISTER NUMBER.
- 2) The ST300 will automatically load the Learned clips on the Learned VTRs, cue the clips to the Learned time, then set the Learned GANG mode.

8. TRIGGER

The operator fires a trigger using the Timeline or Run function on the production switcher. The ST300 puts the Video Server into the following modes based on the trigger value:

GRASS VALLEY GROUP

<u>Trigger Value</u>	<u>Mode</u>
0	Play
1	Recue to beginning of clip
2	Slo-mo using ST300 Preset Speed
3	Reverse Play
4	Still Frame
5	None
6 or greater	Play

SONY

<u>Trigger Value</u>	<u>Mode</u>
0	Recue to beginning of clip Play
1	Play
2	Slo-mo using ST300 Preset Speed
3	Reverse Play
4	Still Frame
5	None
6 or greater	Play

To control more than one VTR, enable the Peripheral Device Address for the required VTRs. The Trigger will be sent to the enabled devices.

OR

GANG the required VTRs on the ST300. See the Menu Table for GANG instructions. Enable the Peripheral Device Address for one of the GANGed VTRs. The Trigger will be sent to the enabled VTR. The other VTRs in the GANG will perform the same action.

Advanced Features . . .

9. SET RECORD DURATION

NOTE: Set Record duration BEFORE creating a new clip, not before going into record.

1. Press **[SHIFT] + [RECORD]**. The first line of the display shows current record duration. The second line of the display prompts “Enter record length.”
2. Enter the desired record length using numeric keypad.
3. Press **[ENTER]** to save the entered time and exit.

OR

Press **[ESC]** to exit without saving.

Default record duration is 30 minutes.

10. CREATE NEW CLIPS

- a. Select VTR. Connection must be to the Recorder port on the MAV-555.
- b. Press **[CLIP LIST]**. The CLIP LIST indicator will turn on. The display will show “Enter new file name.”
- c. Enter a CLIP ID (up to 8 characters) using the numeric keypad **OR** the SHOTBOX “qwerty” keyboard:
- d. Press **[LOAD]** to create the selected CLIP ID.

OR

Press **[ESC]** to exit at anytime.

NOTE: The only functions available for new clips are RECORD and STOP. In order to playback a newly recorded clip, it must be reloaded on a Player port.

11. SETTING THE IN (OUT) POINT

a. MARKING THE IN (OUT) POINT

- 1) Locate the clip to the desired IN (OUT) time.
- 2) Press **[IN]** (**[OUT]**).
The IN (OUT) indicator turns on.
OR
Press **[SHIFT] + [IN]** (**[OUT]**) to manually enter a new IN (OUT) time.
- 3) Press **[ENTER]** to save the entered time or press **[ESC]** to exit without saving.

NOTE: When manually entering **IN** and **OUT** points, they are always marked based on tape time, not LTC, no matter what time mode is selected.

b. VIEW THE IN (OUT) POINT

- 1) When the IN (OUT) indicator is on,
Press **[IN]** (**[OUT]**) to view the existing IN (OUT) Point.
- 2) While viewing the IN (OUT) Point:
Press **[MARK]** to overwrite the saved time with the current time.
Press **[RECUE]** to search to the IN (OUT) point.

c. CLEARING AN IN (OUT) POINT

Press and hold **[DEL]** then press and release **[IN]** (**[OUT]**).
The IN (OUT) indicator turns off.

12. ENTER PREROLL VALUE

- a. Press **[MENU]** and turn the Wheel to “Enter PREROLL:”.
- b. Enter the desired preroll value using the ST300’s numeric keypad.
- c. Press **[ENTER]** to save the entered value.
OR
Press **[ESC]** to exit without saving.

13. TRIMMING CLIPS

- a. LOAD a clip that you want to trim.
- b. Mark IN and OUT Points as described above.
- c. Press **[SHIFT] + [CLIP LIST]**. The display prompts “Enter new file name.”
- d. Enter new file name (up to 8 characters) using the numeric keypad.
- e. Press **[ENTER]** or **[LOAD]** to save the new CLIP ID.
OR
Press **[ESC]** to exit without saving.

If the saving is successful, the new clip is created. The beginning of the clip is the marked IN point, the end of the clip is the OUT point. You can load the new clip using the CLIP LIST function. Upon saving the new clip, marked IN and OUT points are cleared.

NOTE: Do not create trimmed clips with a duration of less than 18 frames.

14. LOOPING A CLIP

- a. Press **[LOOP ENABLE]**. The indicator turns on.
- b. The clip is now in the loop mode. Pressing **[PLAY]**, **[SLOMO]**, **[FFWD]**, etc., will cause the clip to play to the end and wrap around to the beginning.
- c. To return to normal mode, press **[LOOP ENABLE]**. The indicator will turn off.

15. VIEW CONTENT OF CUE POINTS

- a. Press **[VIEW]**. The VIEW indicator turns on.
- b. Press the switch for which you would like to see the content.
- c. The switch turns RED and the content (CLIP ID) of the corresponding Cue Point is displayed on a virtual display.

For Example:

VTR 1 Clip 23	VTR 2 Clip 13	VTR 3 Clip 77	VTR 4 No Assignment
--------------------------------	--------------------------------	--------------------------------	--

Note: All the remaining switches are not illuminated.

- d. Release the keys to return to normal operation.

16. SHOTBOX SHOTKEY MAPPING TO SHOTLIST LOCATIONS

The SWITCHES on the SHOTBOX access the SHOTLIST locations as follows:

BANK 0, SWITCHES 1 → 30 access SHOTLIST locations 001 → 030.
BANK 1, SWITCHES 1 → 30 access SHOTLIST locations 101 → 130.
BANK 2, SWITCHES 1 → 30 access SHOTLIST locations 201 → 230.
BANK 3, SWITCHES 1 → 30 access SHOTLIST locations 301 → 330.
BANK 4, SWITCHES 1 → 50 access SHOTLIST locations 401 → 430.
BANK 5, SWITCHES 1 → 30 access SHOTLIST locations 501 → 530.
BANK 6, SWITCHES 1 → 30 access SHOTLIST locations 601 → 630.
BANK 7, SWITCHES 1 → 30 access SHOTLIST locations 701 → 730.

17. SHOTBOX CONTROL SWITCHES

- a. [PLAY]: Plays out the selected clip.
- b. [RECUE]: Returns to the beginning of the clip.
- c. [STOP]: Stops payout of the clip.

18. PBIO TO CUE POINT MAPPING

Register 0-30	→	Cue Point 0-30
Register 31-60	→	Cue Point 101-130
Register 61-90	→	Cue Point 201-230
Register 91-99	→	Cue Point 301-309

19. TRANSFERRING CUELIST

a. TRANSMIT CUELIST FUNCTION

The TRANSMIT CUELIST function allows you to transmit your list of Cue Points to a PC, using the provided utility software on the PC, or to another ST300. Transfer to a PC requires OpSuite 3.0 software, which runs on a Windows-based computer. Contact DNF Controls for more information.

1) To Transmit Cue Points to the ST300

- a) Connect the VTR 4 connector on the rear of the ST300 to the VTR4 connector of the receiving ST300 using an RS422 9-pin cable with TX and RX lines crossed.
(A “turnaround” cable)
- b) Press [**MENU**].
- c) Scroll the Wheel until “Transmit CUE List? YES=Enter, Exit=ESC” is displayed.
- d) Press [**ENTER**] to start transmitting.
The Display shows “Waiting to transmit” on the first line.
- e) When the Receiver is ready, transfer starts automatically.
The Display now shows “Transmitting cuelist.”
- f) After the transfer is over the display shows “Transfer is over” for one second, then shows “Waiting to transmit” again.
- g) Connect another ST300 to transmit the list again.
OR
Press [**ESC**] twice to exit the MENU mode.

2) To Transmit Cue Points to the PC

- a) Connect the VTR4 connector on the back of the ST300 to one of the COM ports on the PC using a RS422 to RS232 adapter.
- b) Repeat steps b-g of the TRANSMIT CUE POINTS to the ST300 section.

b. RECEIVE CUELIST FUNCTION.

The RECEIVE CUELIST function allows you to receive your list of Cue Points from a PC or from another ST300. Transfer to a PC requires OpSuite 3.0 software, which runs on a Windows-based computer. Contact DNF Controls for more information.

1) To Receive Cue Points from the ST300

- a) Connect the VTR4 connector on the back of the ST300 from the VTR4 connector of the transmitting ST300 using RS422 9-pin cable with TX and RX lines crossed.
A “Turnaround” Cable)
- b) Press [**MENU**].
- c) Scroll the Wheel until “Receive CUE List? YES=Enter, Exit=ESC” is displayed.
- d) Press [**ENTER**] to start receiving.
The Display shows “Waiting to receive” on the first line.
- e) When the Transmitter is ready, transfer starts automatically.
The Display now shows “Receiving cuelist.”
- f) After the transfer is over the display shows “Done-Success! Press any key...”
- g) Press any key. The display shows “Receive cuelist?” message.
- h) Press [**ESC**] to exit the MENU mode.

2) To Receive Cue Points from the PC

- a) Connect the VTR4 connector on the back of the ST300 to one of the COM ports on the PC using RS422 to RS232 adapter.
- b) Repeat steps b-h of the RECEIVE CUE POINTS from the ST300 section.

Reference . . .

20. SETUP MENU

Press [MENU]. The MENU indicator will turn on.

Turn the Wheel to select item to change.

Press [MENU] **OR** use the Softkeys to change the desired mode for that option.

Turn the Wheel at anytime to select another item.

Press [ESC] at anytime to exit SETUP MENU. The MENU indicator will turn off.

<u>MENU MODES</u>	<u>(Turning Wheel Clockwise)</u>								
RECORD	Press [MENU] to select the desired record mode: Crash (Full) or Lockout.								
WIND MODE	Press Softkey to select: HOLD (Fast wind is maintained only while key is depressed.) OR LATCH (Fast wind is initiated and maintained with momentary key press.) Select fast wind speed (3.9 to 23.7) by pressing Softkey below SPD.								
SLOMO	<div style="display: flex; flex-direction: column;"> <div style="display: flex; justify-content: space-between; border: 1px solid black; padding: 5px; margin-bottom: 10px;"> <div style="width: 40%;">ST300 display shows (Non T-Bar version):</div> <div style="width: 55%;"> <table style="width: 100%; border-collapse: collapse;"> <tr> <td style="width: 60%;">SLOMO with:</td> <td style="width: 40%;">WHEEL</td> </tr> <tr> <td>SpdRange</td> <td>Preset</td> </tr> </table> </div> </div> <div style="display: flex; justify-content: space-between; border: 1px solid black; padding: 5px;"> <div style="width: 40%;">ST300 display shows (T-Bar version):</div> <div style="width: 55%;"> <table style="width: 100%; border-collapse: collapse;"> <tr> <td style="width: 60%;">SLOMO with:</td> <td style="width: 40%;">TBAR</td> </tr> <tr> <td>Wheel Speed</td> <td>Preset</td> </tr> </table> </div> </div> <p>Press Softkey [<i>TBAR</i>] (or [<i>WHEEL</i>]) to toggle between them.</p> <p>NOTE: The T-BAR has a fixed speed range of 0 → +200 with a detent at +100% play speed.</p> <p>For Wheel only: Press Softkey [<i>SPDRANGE</i>] to select SLOMO speed ranges: Press Softkey to select: 0 → +200 OR -100 → +200.</p> <p>Press Softkey [<i>BACK</i>] to return to SLOMO MENU. Press [ESC] to exit OR turn the Wheel to select another item.</p> <p>For Wheel only: Press Softkey [<i>PRSET</i>] to select the SLOMO Preset Speed Mode.</p> <p>Press Softkey [<i>UPDATE</i>] when exiting SLOMO mode, the last used speed is saved in the Preset Speed register.</p> <p>Press Softkey [<i>STATIC</i>]. The Preset Speed register is NOT updated when exiting SLOMO mode.</p> <p>It is only changed by [<i>SHIFT</i>] + [<i>SLOMO</i>] (PRESET SLOMO).</p> </div>	SLOMO with:	WHEEL	SpdRange	Preset	SLOMO with:	TBAR	Wheel Speed	Preset
SLOMO with:	WHEEL								
SpdRange	Preset								
SLOMO with:	TBAR								
Wheel Speed	Preset								

ST300 SETUP	<div style="border: 1px solid black; padding: 5px; margin: 10px auto; width: fit-content;"> <p style="text-align: center;">ST300 SETUP</p> <p style="text-align: center;">Clear Cues SetDefault</p> </div> <p>Press Softkey beneath ClearCues to clear all Cue Points to 00:00:00:00. Press Softkey [YES] when asked “Are You Sure?”</p> <p>Press Softkey beneath SetDefault to set ST300 to default settings. Press Softkey [YES] when asked “Are You Sure?”</p>
DISPLAY SOFTWARE VERSION	The version number for the currently installed software is displayed.
SYNC	Set to ON if black burst is supplied to the Ref Video connector on the rear panel. Set to OFF if no black burst is supplied.
VIDEO STANDARD	Sets Video Standard option to NTSC when [NTSC] is pressed. OR Sets Video Standard option to PAL when [PAL] is pressed.
RECALL MODE	Press [NORMAL] or [REDIR] (redirect). NORMAL – The cue point will load on the learned VTR. REDIR – When one and only one clip is learned into a Cue Point, the Clip will be REDIRECTED to load on the currently selected VTR.
PARITY	Select ODD, EVEN or NONE. This is the parity sent via the Peripheral Bus to the ST300.
RECORD	Press Softkey to select single-button or 2-button record. RECORD = [REC] Only OR [REC] + [PLAY].
PBIO ADDRESS	Select to match the switcher output. (ALL hardware versions)
SWITCHER TYPE	Select to match the switcher type. (ALL Hardware versions).
TRANSMIT CUELIST	Transmit cuelist to another ST300 or to a PC.
RECEIVE CUELIST	Receive cuelist from another ST300 or PC.

21. FUNCTION TABLE

Function	Key Press	Description
GOTO ENTERED TIME	[SHIFT] + [RECUE]	Search the VTR to the manually entered time. Use the ST300 numeric keypad. Press [ENTER] or [RECUE].
FFWD	[FFWD]	Press and HOLD to shuttle. Release key to stop. Set WIND Speed in MENU.
JOG	[JOG]	Select JOG mode and enable Wheel.
LAST CUE	[LAST CUE]	Step to the previous Cue Point Location.
NEXT CUE	[NEXT CUE]	Step to the next Cue Point Location.
RECORD	[REC]	Places VTR into the Record mode selected by RECORD MODE in the SETUP MENU. Press [RECORD] OR [RECORD] + [PLAY].
REWIND	[RWD]	Press and HOLD to shuttle. Release key to stop. Set WIND Speed in MENU.
SHUTTLE	[SHUTTLE]	Select SHUTTLE mode and enable Wheel.
SLOMO	[SLOMO]	Press [SLOMO] to slo-mo the VTR. Turn the Wheel (or move the T-Bar, if available) to change the play speed. Press [SLOMO] to STILL frame OR press any transport key to exit SLOMO.
SLO-MO SPEED PRESET	[SHIFT] + [SLOMO]	For WHEEL ONLY: Press [SHIFT] + [SLOMO] to preset the slo-mo speed. Turn the Wheel to select desired speed. Press [ESC] or any transport key to exit.
STOP	[STOP]	Press once to STILL frame VTR. Press again to put VTR into STOP mode.
GANG VTRs	[SHIFT] + [VTR#1] OR [SHIFT] + [VTR#2] OR [SHIFT] + [VTR#3]	Press VTR keys to include in the gang. Press [ESC] to escape gang setup mode. Flashing LED indicates VTR being monitored for status.
TIME MODE SELECT	[TIME MODE]	Press to toggle between Timecode (TC), VITC (VT) or Tape Timer (TM) display modes.
LOOP CLIP	[LOOP ENABLE]	Press to loop a clip.

22. SPECIFICATIONS

ST300

Power:	90 VAC to 265 VAC adapter supplied with IEC connector
Size: (approx.)	(L" x W" x H") 12" x 6" x 1.5" (front) 3.0" (rear)
Weight:	4 lbs.
Rear Panel Connectors:	VTR1, VTR2, VTR3, VTR4.....All DB9F GPI.....DBF15F Power.....DB9M AuxDB9F
Display:	Easy to read 2-line, back-lit LCD display (User adjustable contrast)
Jog/Shuttle Wheel:	With mechanical detents.
Optional "T"-bar:	Slo-mo 0-200% of Play Speed

RS422 SERIAL CONNECTOR

9-Pin D-Type, Female

Pin #	1	Frame Ground	6	Receive Common
	2	Receive A ←	7	Receive B ←
	3	Transmit B →	8	Transmit A →
	4	Transmit Common	9	Frame Ground
	5	Spare		

POWER CONNECTOR

9-Pin D-Type, Male

Pin #	1	+5v DC	6	+5 VDC
	2	+5v DC	7	Ground
	3	Ground	8	Ground
	4	+12 VDC	9	Ground
	5	-12 VDC		

AUX PORT RS422 SERIAL CONNECTOR

9-Pin D-Type, Female

Pin #	1	Frame Ground	6	Transmit Common
	2	Receive A ←	7	Receive B ←
	3	Transmit B →	8	Transmit A →
	4	Receive Common	9	Frame Ground
	5	Spare		

GPI IN/OUT CONNECTOR

15-Pin D-Type, Female (DB15F)

Pin #	Description	Function	Pin #	Description	Function
1	GPI 1 Out		9	GPI 1 In	Play
2	GPI 2 Out		10	GPI 2 In	Stop
3	GPI 3 Out		11	GPI 3 In	Recue
4	GPI 4 Out		12	GPI 4 In	Next Cue
5	GPI 5 Out		13	GPI 5 In	Last Cue
6	GPI 6 Out		14	GPI 6 In	Recall
7	GPI 7 Out		15	GPI 7 In	
8	Ground				

ST420 (SHOTBOX)

Power: 90 VAC to 265 VAC adapter supplied with IEC connector

Size (approx.): (L" x W" x H") 12" x 7 1/4" x 1 1/2" (front) 3 5/8" (rear)

Weight : 5.5 lbs.

Rear Panel Connectors: Power.....DB9M
 OUTPUTDB9F
 Aux.....DB9F

Display: LCD on each key

POWER CONNECTOR

9-Pin D-Type, Male

Pin #	1	+5v DC	6	No Connection
	2	+5v DC	7	Ground
	3	Ground	8	Ground
	4	No Connection	9	Ground
	5	No Connection		

AUX PORT RS422 SERIAL CONNECTOR

9-Pin D-Type, Female

Pin #	1	Frame Ground	6	Transmit Common
	2	Receive A ←	7	Receive B ←
	3	Transmit B →	8	Transmit A →
	4	Receive Common	9	Frame Ground
	5	Spare		

23. TROUBLESHOOTING

ST420 TROUBLESHOOTING

- a. All keys are RED - No communication with ST300.
- b. All keys are dark - No communication between the ST300 and the Video Server.
- c. The version of the ST420 must comply in the software version with the ST300 it is connected to.

To determine the software version of the ST420 do the following:

- 1) Press **[SHIFT]** + **[STOP]** + **[PLAY]**.
The key that displays the current version is RED.
- 2) The ST420 displays:
“SELECT ST300 V2.1 or V2.0 or V3.0.”

Press the key for the software version of ST300 you are using. Please refer to the ST300 to determine the Version if needed.

24. DNF CONTROLS LIMITED WARRANTY

DNF Controls warrants its product to be free from defects in material and workmanship for a period of one (1) year from the date of sale to the original purchaser from DNF Controls.

In order to enforce the rights under this warranty, the customer must first contact DNF's Customer Support Department to afford the opportunity of identifying and fixing the problem without sending the unit in for repair. If DNF's Customer Support Department cannot fix the problem, the customer will be issued a Returned Merchandise Authorization number (RMA). The customer will then ship the defective product prepaid to DNF Controls with the RMA number clearly indicated on the customer's shipping document. The merchandise is to be shipped to:

DNF Controls
12843 Foothill Blvd., Suite D
Sylmar, CA 91342
USA

Failure to obtain a proper RMA number prior to returning the product may result in the return not being accepted, or in a charge for the required repair.

DNF Controls, at its option, will repair or replace the defective unit. DNF Controls will return the unit prepaid to the customer. The method of shipment is at the discretion of DNF Controls, principally UPS Ground for shipments within the United States of America. Shipments to international customers will be sent via air. Should a customer require the product to be returned in a more expeditious manner, the return shipment will be billed to their freight account.

This warranty will be considered null and void if accident, misuse, abuse, improper line voltage, fire, water, lightning or other acts of God damaged the product. All repair parts are to be supplied by DNF Controls, either directly or through its authorized dealer network. Similarly, any repair work not performed by either DNF Controls or its authorized dealer may void the warranty.

After the warranty period has expired, DNF Controls offers repair services at prices listed in the DNF Controls Price List. DNF Controls reserves the right to refuse repair of any unit outside the warranty period that is deemed non-repairable.

DNF Controls shall not be liable for direct, indirect, incidental, consequential or other types of damage resulting from the use of the product.

###