



12843 Foothill Blvd.,  
Suite D  
Sylmar, CA 91342  
818 898 3380 voice  
818 898 3360 fax  
[www.dnfcontrols.com](http://www.dnfcontrols.com)

# **Model No. ST300-S/SM and ST300-S/SM-T**

## **SLOW MOTION CONTROLLER**

*WITH AUTOEDIT OPTION*

## **USER MANUAL**

# Table of Contents

<b>1.</b>	<b>REVISION HISTORY</b>	<b>3</b>
<b><u>GETTING STARTED . . .</u></b>		<b><u>4</u></b>
<b>2.</b>	<b>SYSTEM DESCRIPTION</b>	<b>4</b>
	DEFINITIONS	4
<b>3.</b>	<b>INSTALLATION</b>	<b>5</b>
<b>4.</b>	<b>OPERATION</b>	<b>6</b>
	a. LCD DISPLAY	6
	b. TRANSPORT CONTROL	6
	c. CUE POINTS	7
	d. GOTO/PREROLL TO A MANUALLY ENTERED TIME	7
	e. RECORD MODE SELECTION	8
<b>5.</b>	<b>AUTOEDIT</b>	<b>9</b>
	a. TO SET AN IN (OUT) POINT	9
	b. TO VIEW THE IN (OUT) POINT	9
	c. TO CLEAR THE IN (OUT) POINT	9
	d. TO SET THE PREROLL VALUE OF THE VTR	9
	e. PREVIEW FUNCTION	9
	f. AUOEDIT FUNCTION	9
	g. TRIM THE IN (OUT) POINT	9
<b><u>ADVANCED FEATURES . . .</u></b>		<b><u>10</u></b>
<b>6.</b>	<b>TRANSFER CUELIST</b>	<b>10</b>
	a. TRANSMIT CUE LIST FUNCTION	10
	b. RECEIVE CUE LIST FUNCTION	11
<b><u>REFERENCE . . .</u></b>		<b><u>12</u></b>
<b>7.</b>	<b>SETUP MENU</b>	<b>12</b>
<b>8.</b>	<b>FUNCTION TABLE</b>	<b>15</b>
<b>9.</b>	<b>SPECIFICATIONS</b>	<b>17</b>
	RS422 SERIAL CONNECTOR	17
	POWER CONNECTOR	17
	AUX PORT RS422 SERIAL CONNECTOR	17
	GPI IN/OUT CONNECTOR	18
<b>10.</b>	<b>KEY LAYOUT</b>	<b>19</b>
<b>11.</b>	<b>DNF CONTROLS LIMITED WARRANTY</b>	<b>20</b>

Manual Version:.....1.21 051106  
Document ID:.....ST300-SSM-Autoedit\_User\_Manual.doc

# 1. REVISION HISTORY

111403	1.0	Original document.
060204	Rev. 1.1	Corrected T-bar size, SPECIFICATIONS.
011005	Rev. 1.2	Removed Search Speed menu option. Added 24P processing.
051106	Rev. 1.21	Added "save record mode"

# *Getting Started . . .*

## **2. SYSTEM DESCRIPTION**

Slow Motion Controller that you can configure for the way you work.

Controls up to 4 VTRs.

T-BAR or detented Wheel for Fast and Easy slomo-ing:  
0-200% or -100% to + 200% of Play speed.

Quickly and easily store and recall 400 Cue Points - 100 per VTR. All Cue Points are retained when power is off.

Fast and easy to search to a Cue Point, manually entered Timecode number or Record out Point.

Set Preroll duration from one frame to one hour.

### **DEFINITIONS**

- ❑ Throughout this document VTR, DDR, VDR & Video Server will be referred to collectively as "VTR."
- ❑ The ST300-S/SM as the ST300.
- ❑ Words surrounded by brackets, for example, [ENTER], are keys on the ST300.
- ❑ [XXX] + [XXX] means hold the two keys down simultaneously.

### 3. INSTALLATION

- a. Plug one end of a 9-conductor, RS422 serial cable into the VTR1, VTR2, VTR3, OR VTR4 connector on the rear of the SLOW MOTION CONTROLLER. Plug the other end of the cable into the 9-pin REMOTE connector on the VTR.
- b. Connect the supplied POWER SUPPLY, APX#4108, into the POWER connector on the rear of the ST300. Plug the Power Supply into an outlet, 90 VAC – 240 VAC.
- c. Select REMOTE mode on the VTR's front panel.
- d. Check the **SETUP MENU** prior to using the Slow Motion Controller to confirm proper Record mode, SLO-MO speed range, and other User settable modes.
- e. Select “Slomo SPD: DVC” only if you are controlling a DVCPro VTR.

### CONNECTION DIAGRAM

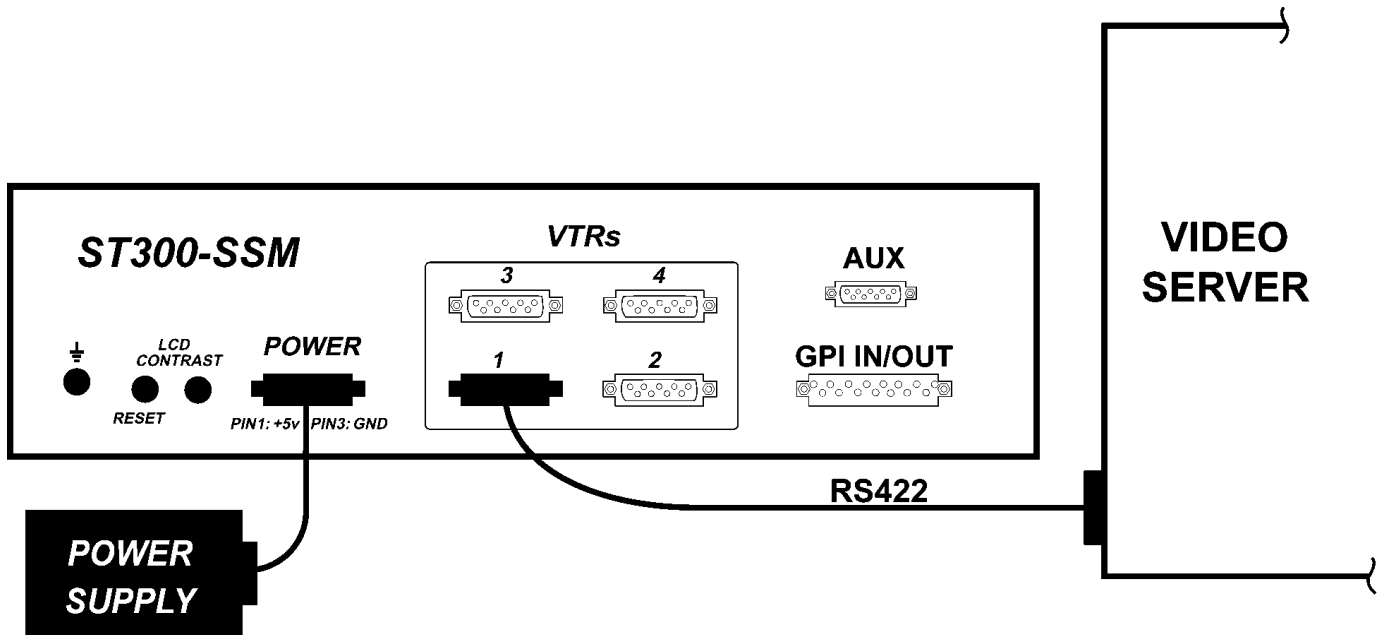

Note: The Reference Video connector has no function.

## 4. OPERATION

### a. LCD DISPLAY

During normal operation, the top row of the display shows the selected time mode and current time location of the selected VTR.

For example: TM 01:12:09:23

Time Modes - TM= Tape Timer TC= LTC VT= VITC

The currently selected SLO-MO speed is displayed on the far right side of the top row.

The bottom row of the display shows the current Cue Point number and its contents.

### b. TRANSPORT CONTROL

Select the desired transport function by pressing the appropriate switch on the SLOW MOTION CONTROLLER.

The Real-Time Status Indicators will light to indicate the VTR's current tape transport mode.

For example: Pressing [**PLAY**] will put the VTR into the PLAY mode.  
The PLAY Status Indicator will turn on when the VTR is in PLAY mode.  
Press [**RECORD**].  
**OR**

[**RECORD**] + [**PLAY**] to put the VTR into Record mode (see SETUP MENU).

**NOTE:** The VTR will not go into Record mode if “Record Inhibit” is enabled on the VTR or tape cassette.

Check SETUP MENU prior to using the SLOW MOTION CONTROLLER to confirm proper Record mode and other User settable modes.

## c. CUE POINTS

### 1) Select a Cue Point

Press [NEXT CUE] or [LAST CUE] to step through the Cue Points.  
**OR**

Manually enter the desired Cue Point number using the numeric keypad.

The current Cue Point number and its contents will be shown on the second line of the display.

### 2) Mark/Enter/Edit a Cue Point

Press [MARK] to mark the VTR's time into the Cue Point.  
**OR**

Press [ENTER TIME] to use the numeric keypad. The ENTER TIME indicator will turn on.

Manually enter a time on the numeric keypad. Press [ENTER] to save the entered time.  
**OR**

Press [ESC] to exit without saving. The ENTER TIME indicator will turn off.

### 3) Goto/Preroll to a Cue Point

a) Select the desired Cue Point. The Cue number and its contents are shown on the bottom line of the display.

b) Press [GOTO] to search to the Cue Point; the GOTO indicator will turn on. When the VTR reaches the Cue Point time, the GOTO indicator will turn off.  
**OR**

Press [PREROLL] to preroll to the Cue Point. The PREROLL indicator will turn on.

When the VTR reaches the Cue Point time, the PREROLL indicator will turn off.

## d. GOTO/PREROLL TO A MANUALLY ENTERED TIME

1) Press [ENTER TIME] to use the numeric keypad.

Manually enter a time on the numeric keypad.

2) Press [GOTO] OR [PREROLL] to search to the entered time.  
**OR**

Press [ESC] to exit without searching.  
The ENTER TIME indicator will turn off.

**e. RECORD MODE SELECTION**

- 1) Press [MENU]. The MENU indicator will turn on.
- 2) Turn the Wheel until “REC” is viewed on the top line of the display. The current Record mode is shown.
- 3) Press [MENU] to select:  
**Record Lockout, Assemble, Crash or Insert** Record mode.
- 4) INSERT ONLY - Press the desired Softkey to toggle Video, Audio1, Audio2, Audio3 or Audio4 record on/off.

The **Softkeys** are located just below the display.  
Follow the line graphic from the bottom of the display to the Softkey.

- 5) Press [ESC] to exit the MENU. The MENU indicator will turn off.  
**OR**

Turn the Wheel for other setup options.

## 5. AUTOEDIT

### a. TO SET AN IN (OUT) POINT

Press **[IN]** (**[OUT]**) to set an AUTOEDIT IN (OUT) Point.  
The IN (OUT) key indicator on the ST300 will turn on.

### b. TO VIEW THE IN (OUT) POINT

The IN (OUT) key indicator will be lit when and IN (OUT) point has been set.  
Press **[IN]** (**[OUT]**) to view the existing IN (OUT) point.

While viewing the IN (OUT) point:

Press **[GOTO]** to search to the IN (OUT) point.

Press **[PREROLL]** to preroll to the IN (OUT) point.

Press **[DEL]** + **[IN]** (**[OUT]**) to clear the IN (OUT) point.

### c. TO CLEAR THE IN (OUT) POINT

Press and hold **[DEL]**. Press and release **[IN]** (**[OUT]**).  
The IN (OUT) key indicator will turn off.

### d. TO SET THE PREROLL VALUE OF THE VTR

Press **[SHIFT]** + **[PREROLL]** to set the Preroll Value of the VTR.

### e. PREVIEW FUNCTION

After setting the IN and optional OUT points,  
press **[SHIFT]** + **[PLAY]** to preview the AutoEdit.

### f. AUTOEDIT FUNCTION

After setting the IN and optional OUT Points,  
press **[SHIFT]** + **[RECORD]** to perform the AutoEdit.

### g. TRIM THE IN (OUT) POINT

- 1) MARK or ENTER the IN (OUT) point.
- 2) Press **[SHIFT]** + **[IN]** (**[OUT]**).  
The first line of the display shows "Trim IN (OUT): xx:xx:xx:xx,"  
Where xx:x:xx:xx – current IN (OUT) point.  
The second line of the display shows the prompt "FWD→, RWD←, ESC-exit"
- 3) Press **[FFWD]** to increment the IN (OUT) time 1 frame.
- 4) Press **[REW]** to decrement the IN (OUT) time 1 frame.
- 5) Press **[ESC]** to exit the Trim mode.

## *Advanced Features . . .*

### **6. TRANSFER CUELIST**

#### **a. TRANSMIT CUE LIST FUNCTION**

The TRANSMIT CUE LIST function allows you to transmit your list of Cue Points to a PC, using the provided utility software on the PC, or to another ST300. Transfer to a PC requires OpSuite 3.0 software, which runs on a Windows-based computer. Contact DNF Controls for more information.

##### **1) To Transmit Cue Points to Another ST300:**

- a) Connect the VTR4 connector on the rear of the ST300 to the VTR4 connector of the receiving ST300 using an RS422 9-pin cable with TX and RX lines crossed. (A “turnaround” cable.)
- b) Press [MENU].
- c) Scroll the Wheel until “Transmit CUE list? YES=Enter, Exit=ESC” is displayed.
- d) Press [ENTER] to start transmitting. The Display shows “Waiting to transmit” on the first line.
- e) When the Receiver is ready, transfer starts automatically. The Display now shows “Transmitting cuelist.”
- f) After the transfer is over, the display shows “Transfer is over” for one second and then shows “Waiting to transmit” again.
- g) Connect another ST300 to transmit the list again.  
**OR**

Press [ESC] twice to exit the MENU mode.

##### **2) To Transmit Cue Points to a PC:**

- a) Connect the VTR4 connector on the back of the ST300 to one of the COM ports on the PC using a RS422 to RS232 adapter.
- b) Repeat steps a) thru g) of “**To Transmit Cue Points to Another ST300,**” Section 5.a.1).

## **b. RECEIVE CUE LIST FUNCTION**

The RECEIVE CUE LIST function allows you to receive a list of Cue Points from a PC or from another ST300. Transfer to a PC requires OpSuite 3.0 software, which runs on a Windows-based computer. Contact DNF Controls for more information.

### **1) To Receive Cue Points From Another ST300:**

- a) Connect the VTR4 connector on the back of the ST300 from the VTR4 connector of the transmitting ST300 using RS422 9-pin cable with TX and RX lines crossed.  
(A “Turnaround” Cable)
- b) Press [**MENU**].
- c) Scroll the Wheel until “Receive CUE List? YES=Enter, Exit=ESC” is displayed.
- d) Press [**ENTER**] to start receiving.  
The Display shows “Waiting to receive” on the first line.
- e) When the Transmitter is ready, transfer starts automatically. The Display now shows “Receiving cuelist.”
- f) After the transfer is over the display shows “Done-Success! Press any key...”
- g) Press any key. The display shows “Receive cuelist?” message.
- h) Press [**ESC**] to exit the MENU mode.

### **2) To Receive Cue Points from the PC.**

- a) Connect the VTR4 connector on the back of the ST300 to one of the COM ports on the PC using RS422 to RS232 adapter.
- b) Repeat steps a) thru h) of “**To Receive Cue Points From Another ST300,**” Section 5.b.1).

## Reference . . .

### 7. SETUP MENU

- ❑ Press [**MENU**]. The MENU indicator will turn on. Turn the Wheel to select item to change.
- ❑ Use the Softkeys to change the desired mode for that option. Turn the Wheel at anytime to select another item.
- ❑ Press [**ESC**] at anytime to exit **SETUP MENU**. The MENU indicator will turn off.

<b><u>MENU MODES</u></b>	<b><u>(Turning Wheel Clockwise)</u></b>
<b>RECORD</b>	Press [ <b>MENU</b> ] to select the desired record mode: Lockout, Assemble, Crash (Full) or Insert.  <u>Only</u> in INSERT mode: Press the associated Softkey, located below the display, to toggle Video(V), Audio1(A1), Audio2(A2), Audio3(A3), Audio4(A4) on/off.
<b>SAVE RECORD MODE</b>	Press Softkey to select. NO (record mode will return to lockout after reset). <b>OR</b> YES (record mode will retain selected setting after reset).
<b>MARK-Q</b>	Press Softkey to: Enable ADVANCE to next Cue Point, when [ <b>MARK</b> ] is pressed. <b>OR</b> Maintain CURRENT Cue Point when [ <b>MARK</b> ] is pressed.
<b>WIND MODE</b>	Press Softkey to select: HOLD (Fast wind is maintained only while key is pressed.) <b>OR</b> LATCH (Fast wind is initiated and maintained with momentary key press.)  Select fast wind speed (3.9 to 23.7) by pressing Softkey below SPD.

<u>MENU MODES</u>	<u>(Turning Wheel Clockwise)</u>								
<b>SLOMO</b>	<p>ST300 display shows (T-Bar version):</p> <table border="1" data-bbox="781 201 1221 317"> <tr> <td>SLOMO with:</td> <td>TBAR</td> </tr> <tr> <td>Wheel</td> <td>SpdRange Preset</td> </tr> </table> <p>ST300 display shows (Non T-Bar version):</p> <table border="1" data-bbox="781 373 1221 489"> <tr> <td>SLOMO with:</td> <td>WHEEL</td> </tr> <tr> <td>SpdRange</td> <td>Preset</td> </tr> </table> <p>Press Softkey [TBAR] (or [WHEEL]) to toggle between T-BAR and WHEEL.</p> <p>The T-BAR has two speed ranges:  0 → +200 with a detent at +100 % play speed  <b>OR</b>  0 → +100 with a detent at +100%</p> <p>(Continued on next page)</p> <p><b>For Wheel only:</b>  Press Softkey [SPDRANGE] to select SLOMO speed ranges:</p> <p>Press Softkey to select: 0 → +200 <b>OR</b> -100 → +200.  Press Softkey [BACK] to return to SLOMO MENU.</p> <p>Press [ESC] to exit SETUP MENU  <b>OR</b> turn the Wheel to select another item.</p> <p><b>For Wheel only:</b>  Press Softkey [PRSET] to select the SLOMO Preset Speed Mode.</p> <p>Press Softkey [UPDATE].  When exiting SLOMO mode, the last used speed is saved in the Preset Speed register.</p> <p>Press Softkey [STATIC].  The Preset Speed register is NOT updated when exiting SLOMO mode.  It is only changed by [SHIFT] + [SLOMO] (PRESET SLOMO).</p>	SLOMO with:	TBAR	Wheel	SpdRange Preset	SLOMO with:	WHEEL	SpdRange	Preset
SLOMO with:	TBAR								
Wheel	SpdRange Preset								
SLOMO with:	WHEEL								
SpdRange	Preset								
<b>TBAR AUTOENABLE</b>	Press Softkey [ON] to enable slomo to be engaged by moving the TBAR.								
<b>WHEEL AUTOENABLE</b>	Press Softkey [JOG] or [SHUTTLE] to enable that function to be engaged by turning the Wheel.								
<b>SLOMO SPEED SELECT</b>	<p>Press softkey [CHANGE] to change the SLOMO speed options. The following is a list of all available speed options settings:</p> <p><b>AJD-450:</b> If controlling DVCPro AJD-450/850  <b>AJ-D455:</b> If controlling DVCPro AJ-D455  <b>AJ-SD955:</b> If controlling DVCPro AJ-SD955/930  <b>Standard:</b> If controlling any other VTR. The Standard Set of SLOMO Speeds will be used. (Default Setting)</p>								

<u><b>MENU MODES</b></u>	<u><b>(Turning Wheel Clockwise)</b></u>
<b>GANG MODE</b>	<p>Press Softkey to select PERMANENT GANG (described in the FUNCTION Table) or TEMPORARY GANG.</p> <p>In TEMPORARY mode, press and hold the VTR key that you want to read status from, then press the VTR#s of those VTRs that you want to include in the gang. Release the keys. The LED on the monitored VTR blinks, all other VTRs in the gang stay on constantly. To break the temporary gang, press any VTR# key.</p>
<b>GANG MARK</b>	<p>Press softkey  <b>MASTER</b> (each channel of the gang will receive the same time as the master chain [blinking]).  <b>OR</b>  <b>INDIVIDUAL</b> (each channel of the gang will receive it's own time).</p>
<b>ST300 SETUP</b>	<div data-bbox="477 806 954 909" style="border: 1px solid black; padding: 5px; margin-bottom: 10px;"> <p style="text-align: center;">ST300 SETUP</p> <p style="text-align: center;">Clear Cues                      SetDefault</p> </div> <p>Press Softkey beneath ClearCues to clear all Cue Points to 00:00:00:00.  Press Softkey [<b>YES</b>] when asked “Are You Sure?”</p> <p>Press Softkey beneath SetDefault to set ST300 to default settings.  Press Softkey [<b>YES</b>] when asked “Are You Sure?”</p>
<b>DISPLAY SOFTWARE VERSION</b>	The version number for the currently installed software is displayed.
<b>DROP FRAME</b>	Press Softkey to select DROP FRAME ON or OFF. Used to preset the VTR’s Timecode Generator.
<b>RECORD</b>	Press Softkey to select single button or 2-button record. <b>RECORD = [REC] Only</b> <b>OR</b> <b>RECORD = [REC] + [PLAY]</b>
<b>REC OUT FREEZE</b>	Press Softkey to enable or disable FREEZE at Record Outpoint. Changing mode automatically clears FREEZE point.
<b>VIDEO STANDARD</b>	Sets Video Standard option to NTSC when [ <b>NTSC</b> ] is pressed. <b>OR</b> Sets Video Standard option to PAL when [ <b>PAL</b> ] is pressed. <b>OR</b> Sets Video Standard option to 24P when [ <b>24P</b> ] is pressed.
<b>TRANSMIT CUELIST</b>	Transmits Cuelist to another ST300 or to a PC.

## 8. FUNCTION TABLE

Function	Key Press	Description
EE On/Off	[ <b>EE</b> ]	Toggle EE mode on/off. Status indicator is on when EE is on.
EJECT TAPE	[ <b>SHIFT</b> ] + [ <b>REWIND</b> ]	Eject tape from VTR.
ENTER TIME	[ <b>ENTER TIME</b> ]	To manually enter timecode number into the currently displayed Cue Point, enter the desired timecode number using the numeric keypad. Press [ <b>ENTER</b> ] to save your entry <b>OR</b> [ <b>ESC</b> ] to exit without saving.  To enter a GOTO location without altering the contents of the Cue Point, enter the desired timecode number using the numeric keypad. Press [ <b>GOTO</b> ] to search to the entered time. Press [ <b>ESC</b> ] to exit without searching.
FFWD	[ <b>FFWD</b> ]	Press and HOLD to FFWD. Release key to stop. Set WIND Speed in MENU.
FREEZE ON LAST GOOD VIDEO	Active in SLO-MO only.	In SLO-MO mode, STILL frame the VTR when the current timecode is within 6 frames of the last Record Out point (memorized automatically upon exiting Record mode). Enable, disable or clear the FREEZE point from SETUP MENU. See FREEZE ENABLE.
GOTO CUE or ENTERED TIME	[ <b>GOTO</b> ]	Search the VTR to the contents of the currently displayed Cue Point. If ENTER TIME is active (LED is on), search the VTR to the entered time.  To enter a GOTO location without altering the contents of the Cue Point, Press [ <b>ENTER TIME</b> ]. Enter the desired timecode number using the numeric keypad. Press [ <b>GOTO</b> ] to search to the entered time. Press [ <b>ESC</b> ] to exit without searching.
GANG	[ <b>SHIFT</b> ] + [ <b>VTR#1</b> ] OR [ <b>SHIFT</b> ] + [ <b>VTR#2</b> ] OR [ <b>SHIFT</b> ] + [ <b>VTR#3</b> ] OR [ <b>SHIFT</b> ] + [ <b>VTR#4</b> ]	Individually press the VTR keys to be included in the gang; the LED above the key will turn on. Press the VTR key again to remove from gang; the LED above the key will turn off. Press [ <b>ESC</b> ] to exit.  The VTR LEDs that are on show the gang. The flashing LED shows which VTR is currently selected.
GO TO FREEZE POINT	[ <b>SHIFT</b> ] + [ <b>GOTO</b> ]	Search VTR to FREEZE point (last Record Out point).
JOG	[ <b>JOG</b> ]	Select JOG mode and enable the Wheel.
LAST CUE	[ <b>LAST CUE</b> ]	Step to the previous Cue Point Location.
MARK CUE POINT	[ <b>MARK</b> ]	Save the current time in the currently displayed Cue Point. Per SETUP MENU, the Cue Point Location will advance to the next Cue Point location or remain the same.
NEXT CUE	[ <b>NEXT CUE</b> ]	Step to the next Cue Point Location.

<b>Function</b>	<b>Key Press</b>	<b>Description</b>
PREROLL	[ <b>PREROLL</b> ]	Preroll the VTR to the contents of the currently displayed Cue Point.
PREROLL VALUE	[ <b>SHIFT</b> ] + [ <b>PREROLL</b> ]	Enter desired Preroll Value. Press [ <b>ENTER</b> ] to save entry <b>OR</b> press [ <b>ESC</b> ] to exit without saving entry.
RECORD	[ <b>REC</b> ] or [ <b>REC</b> ] + [ <b>PLAY</b> ]	Places VTR in the Record mode selected by RECORD MODE in the SETUP MENU.
REVERSE PLAY	[ <b>REV</b> ]	For T-BAR ONLY – HOLD key to play video in reverse. RELEASE key to play forward.
REWIND	[ <b>RWD</b> ]	Press and HOLD to rewind. Release key to stop. Set WIND Speed in MENU.
SHUTTLE	[ <b>SHUTTLE</b> ]	Select SHUTTLE mode and enable the Wheel.
SLOMO	[ <b>SLOMO</b> ]	Press SLOMO to slo-mo the VTR. Turn the Wheel or move the T-Bar to change the play speed.  Press SLOMO to STILL frame <b>OR</b> press any transport key to exit.
SLO-MO SPEED PRESET	[ <b>SHIFT</b> ] + [ <b>SLOMO</b> ]	For WHEEL ONLY - to preset the slo-mo speed. Turn the Wheel to select desired speed.  Press [ <b>ESC</b> ] <b>OR</b> any transport key to exit.
STOP	[ <b>STOP</b> ]	Press once to STILL frame VTR. Press again to put VTR into STOP mode.
TIME MODE SELECT	[ <b>TIME MODE</b> ]	Press to toggle between Timecode (TC), VITC (VT) or Tape Timer (TM) display modes.
TIME PRESET (Generator Preset)	[ <b>SHIFT</b> ] + [ <b>TIME MODE</b> ]	Press to enter Time Preset. Press [ <b>ENTER</b> ] to load Time Generator with 00:00:00:00. <b>OR</b> enter the time desired via the numeric keypad and press [ <b>ENTER</b> ] to load that time. <b>OR</b> press [ <b>ESC</b> ] to exit without saving.

## 9. SPECIFICATIONS

Power:	90 VAC to 265 VAC adapter supplied with IEC connector
Size:	(L" x W" x H") 12" x 6" x 1.5" (front) 3.0" (rear) (T-Bar unit is 12.6" long)
Weight:	4 lbs.
Rear Panel Connectors:	VTR1, VTR2, VTR3, VTR4 ..... (All DB9F) GPI ..... (DBF15F) Power ..... (DB9M) Aux ..... (DB9F) Reference Video ..... (BNC)
Display:	Easy to read 2-line, back-lit LCD display (User adjustable contrast)
Jog/Shuttle Wheel	With mechanical detents
Optional "T"-bar	Slo-mo 0-200% of Play Speed

### RS422 SERIAL CONNECTOR

#### 9-Pin D-Type, Female (DB9F)

Pin #	1	Frame Ground	6	Receive Common
	2	Receive A ←	7	Receive B ←
	3	Transmit B →	8	Transmit A →
	4	Transmit Common	9	Frame Ground
	5	Spare		

### POWER CONNECTOR

#### 9-Pin D-Type, Male (DB9M)

Pin #	1	+5v DC	6	+5 VDC
	2	+5v DC	7	Ground
	3	Ground	8	Ground
	4	+12 VDC	9	Ground
	5	-12 VDC		

### AUX PORT RS422 SERIAL CONNECTOR

#### 9-Pin D-Type, Female

Pin #	1	Frame Ground	6	Transmit Common
	2	Receive A ←	7	Receive B ←
	3	Transmit B →	8	Transmit A →
	4	Receive Common	9	Frame Ground
	5	Spare		

## GPI IN/OUT CONNECTOR

### 15-Pin D-Type, Female (DB15F)

Pin #	Description	Function	Pin #	Description	Function
1	GPI 1 Out	PLAY tally out	9	GPI 1 In	PLAY
2	GPI 2 Out	STILL/STOP tally out	10	GPI 2 In	STOP
3	GPI 3 Out	RECORD tally out	11	GPI 3 In	RECORD
4	GPI 4 Out	REWIND tally out	12	GPI 4 In	REWIND
5	GPI 5 Out	FFWD tally out	13	GPI 5 In	FFWD
6	GPI 6 Out	SLOMO tally out	14	GPI 6 In	SLOMO
7	GPI 7 Out		15	GPI 7 In	STILL
8	Ground				

# 10. KEY LAYOUT

## ST300 KEY CONFIGURATION / ST300-S/SM-AUTOEDIT

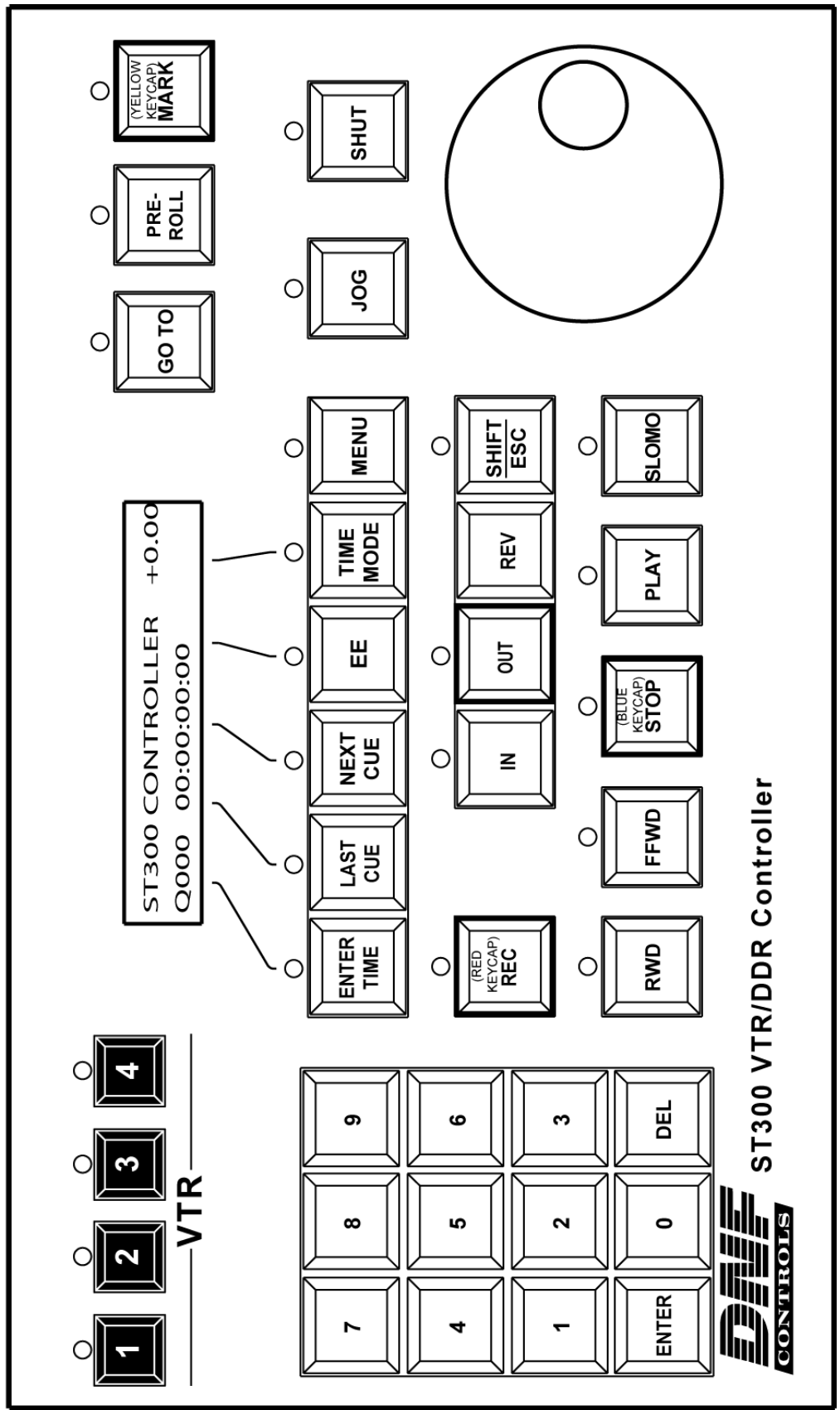

## 11. DNF CONTROLS LIMITED WARRANTY

DNF Controls warrants its product to be free from defects in material and workmanship for a period of one (1) year from the date of sale to the original purchaser from DNF Controls.

In order to enforce the rights under this warranty, the customer must first contact DNF's Customer Support Department to afford the opportunity of identifying and fixing the problem without sending the unit in for repair. If DNF's Customer Support Department cannot fix the problem, the customer will be issued a Returned Merchandise Authorization number (RMA). The customer will then ship the defective product prepaid to DNF Controls with the RMA number clearly indicated on the customer's shipping document. The merchandise is to be shipped to:

DNF Controls  
12843 Foothill Blvd., Suite D  
Sylmar, CA 91342  
USA

Failure to obtain a proper RMA number prior to returning the product may result in the return not being accepted, or in a charge for the required repair.

DNF Controls, at its option, will repair or replace the defective unit. DNF Controls will return the unit prepaid to the customer. The method of shipment is at the discretion of DNF Controls, principally UPS Ground for shipments within the United States of America. Shipments to international customers will be sent via air. Should a customer require the product to be returned in a more expeditious manner, the return shipment will be billed to their freight account.

This warranty will be considered null and void if accident, misuse, abuse, improper line voltage, fire, water, lightning or other acts of God damaged the product. All repair parts are to be supplied by DNF Controls, either directly or through its authorized dealer network. Similarly, any repair work not performed by either DNF Controls or its authorized dealer may void the warranty.

After the warranty period has expired, DNF Controls offers repair services at prices listed in the DNF Controls Price List. DNF Controls reserves the right to refuse repair of any unit outside the warranty period that is deemed non-repairable.

DNF Controls shall not be liable for direct, indirect, incidental, consequential or other types of damage resulting from the use of the product.

###

