



12843 Foothill Blvd.,
Suite D
Sylmar, CA 91342
818 898 3380 voice
818 898 3360 fax
www.dnfcontrols.com

**Model No. ST300-SRP
and ST300-SRP-T
for
DDRs With Simultaneous
Record/Playback Capability
SLOW MOTION CONTROLLER**

USER MANUAL

V 1.41

Table of Contents

1.	REVISION HISTORY	3
	<i>GETTING STARTED . . .</i>	4
<hr/>		
2.	SYSTEM DESCRIPTION	4
	DEFINITIONS	4
3.	INSTALLATION	5
a.	SIMULTANEOUS RECORD/PLAYBACK MODE OFF	5
b.	SIMULTANEOUS RECORD/PLAYBACK MODE ON	5
4.	OPERATION	7
a.	LCD DISPLAY	7
b.	TRANSPORT CONTROL	7
c.	CUE POINTS	8
d.	GOTO/PREROLL TO A MANUALLY ENTERED TIME	9
e.	RECORD MODE SELECTION	9
5.	SIMULTANEOUS RECORD/PLAYBACK FUNCTIONS	10
a.	SELECT SIMULTANEOUS RECORD/PLAYBACK MODE	10
b.	CREATE NEW CLIP	10
b.	STOP RECORD	11
c.	GO TO EE	11
d.	GOTO LIVE	11
	<i>ADVANCED FEATURES . . .</i>	12
<hr/>		
6.	TRANSFER CUELIST	12
a.	TRANSMIT CUE LIST FUNCTION	12
b.	RECEIVE CUE LIST FUNCTION	13
	<i>REFERENCE . . .</i>	14
<hr/>		
7.	SETUP MENU	14
8.	FUNCTION TABLE	17
9.	SPECIFICATIONS	20
	RS422 SERIAL CONNECTOR	20
	POWER CONNECTOR	20
	AUX PORT RS422 SERIAL CONNECTOR	21
	GPI IN/OUT CONNECTOR	21
10.	KEY LAYOUT	22
11.	DNF CONTROLS LIMITED WARRANTY	23

Manual Version:.....1.41 091906

Document ID:.....ST300-SRP_User_Manual.doc

1. REVISION HISTORY

051603	1.0	Original document
123003	Rev. 1.1	Company header information revised. Updated Transmit Cue List Function and Receive Cue List Function Descriptions. Added DNF Controls Limited Warranty.
060204	Rev. 1.2	Updated Connection Diagram. Corrected T-bar size, SPECIFICATION.
111804	Rev. 1.3	Added GOTO LIVE Section. Added Video Standard Selection and INPUT Video Delay Entry to SETUP MENU.
102605	Rev. 1.4	Update to current manual convention
091906	Rev. 1.4 1	Update to include Create New Clip function.

Getting Started . . .

2. SYSTEM DESCRIPTION

The ST300-SRP Slow Motion Controller combines the power of the ST300 Slow Motion Controller with the power of DDRs that have simultaneous record/playback capability.

In the ST300 Setup Menu, disable S-RP Mode to access standard ST300 Slow Motion functions.

Enable SRP Mode to access the following functions:

- ❑ Simultaneous Record and Playback.
- ❑ Press **[EE]** to go to live video.

DEFINITIONS

- ❑ Throughout this document VTR, DDR, VDR & Video Server will be referred to collectively as “VTR.”
- ❑ The ST300-SRP will be referred to as “ST300.”
- ❑ Words surrounded by brackets, for example, **[ENTER]**, are keys on the ST300.
- ❑ Words surrounded by curly brackets, for example, *{DEFAULTS}*, are soft keys under the display.
- ❑ **[XXX] + [XXX]** means hold the two keys down simultaneously.

3. INSTALLATION

Select **a.** OR **b.** below.

a. SIMULTANEOUS RECORD/PLAYBACK MODE OFF

- 1) Plug one end of a 9-conductor, RS422 serial cable into the VTR1, VTR2, VTR3, OR VTR4 connector on the rear of the SLOW MOTION CONTROLLER. Plug the other end of the cable into the 9-pin REMOTE connector on the VTR.
- 2) Connect the supplied POWER SUPPLY, APX#4108, into the POWER connector on the rear of the ST300. Plug the Power Supply into an outlet, 90 VAC – 240 VAC.
- 3) Select REMOTE mode on the VTR's front panel.
- 4) Check the **SETUP MENU** prior to using the Slow Motion Controller to confirm proper Record mode, SLO-MO speed range, and other User settable modes.

OR

b. SIMULTANEOUS RECORD/PLAYBACK MODE ON

- 1) Connect VTR1 connector on the back of the ST300 to the REMOTE connector of playback channel on DDR 1.
- 2) Connect VTR3 connector on the back of the ST300 to the REMOTE connector of record channel on DDR 1.
- 3) Connect VTR2 connector on the back of the ST300 to the REMOTE connector of playback channel on DDR 2.
- 4) Connect VTR4 connector on the back of the ST300 to the REMOTE connector of record channel on DDR 2.
- 5) Connect the supplied POWER SUPPLY, APX#4108 into the POWER connector on the rear of the ST300. Plug the Power Supply into an outlet, 90 VAC – 240 VAC.
- 6) Select REMOTE mode on the DDR's front panel.
- 7) Check the **SETUP MENU** prior to using the Slow Motion Controller to confirm proper Record mode, SLO-MO speed range, and other User settable modes.

SIMULT REC/PB MODE: OFF Connection Diagram

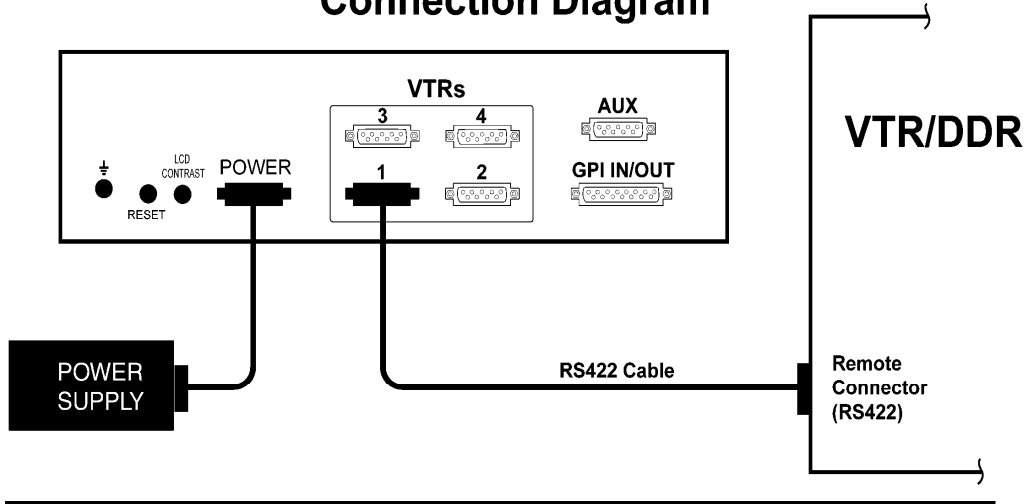

SIMULT REC/PB MODE: ON Connection Diagram

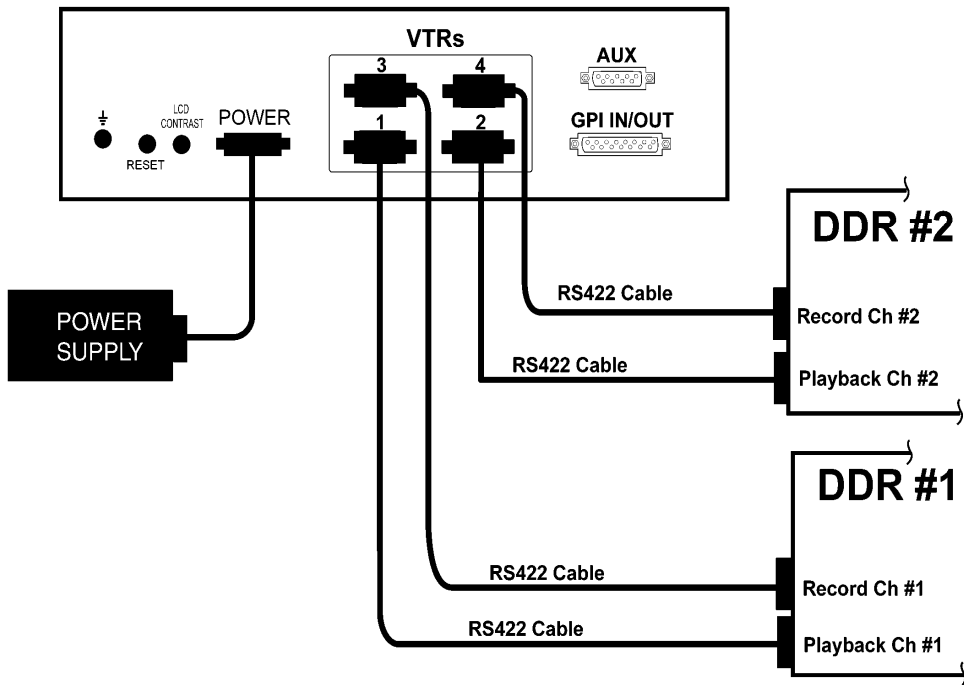

4. OPERATION

a. LCD DISPLAY

During normal operation, the top row of the display shows the selected time mode and current time location of the selected VTR.

For example: TM 01:12:09:23

Time Modes - TM= Tape Timer TC= LTC VT= VITC

The currently selected SLO-MO speed is displayed on the far right side of the top row.

The bottom row of the display shows the current Cue Point number and its contents.

b. TRANSPORT CONTROL

Select the desired transport function by pressing the appropriate switch on the SLOW MOTION CONTROLLER.

The Real-Time Status Indicators will light to indicate the VTR's current tape transport mode.

For example: Pressing **[PLAY]** will put the VTR into the PLAY mode.

The PLAY Status Indicator will turn on when the VTR is in PLAY mode.

Press **[RECORD]**.

OR

[RECORD] + [PLAY] to put the VTR into Record mode (see SETUP MENU).

NOTE: The VTR will not go into Record mode if "Record Inhibit" is enabled on the VTR or tape cassette.

Check SETUP MENU prior to using the SLOW MOTION CONTROLLER to confirm proper Record mode and other User settable modes.

c. CUE POINTS

1) Select a Cue Point

Press **[NEXT CUE]** or **[LAST CUE]** to step through the Cue Points.

OR

Manually enter the desired Cue Point number using the numeric keypad.

The current Cue Point number and its contents will be shown on the second line of the display.

2) Mark/Enter/Edit a Cue Point

Press **[MARK]** to mark the VTR's time into the Cue Point.

OR

Press **[ENTER TIME]** to use the numeric keypad. The **ENTER TIME** indicator will turn on.

Manually enter a time on the numeric keypad. Press **[ENTER]** to save the entered time.

OR

Press **[ESC]** to exit without saving. The **ENTER TIME** indicator will turn off.

3) Goto/Preroll to a Cue Point

a) Select the desired Cue Point. The Cue number and its contents are shown on the bottom line of the display.

b) Press **[GOTO]** to search to the Cue Point; the **GOTO** indicator will turn on. When the VTR reaches the Cue Point time, the **GOTO** indicator will turn off.

OR

Press **[PREROLL]** to preroll to the Cue Point. The **PREROLL** indicator will turn on.

When the VTR reaches the Cue Point time, the **PREROLL** indicator will turn off.

d. GOTO/PREROLL TO A MANUALLY ENTERED TIME

- 1) Press [ENTER TIME] to use the numeric keypad.

Manually enter a time on the numeric keypad.

- 2) Press [GOTO] to search to the entered time.

OR

Press [PREROLL] to search to the entered time minus the preroll time.

OR

Press [ESC] to exit without searching.

The ENTER TIME indicator will turn off.

e. RECORD MODE SELECTION

- 1) Press [MENU]. The MENU indicator will turn on.

- 2) Turn the Wheel until “REC” is viewed on the top line of the display. The current Record mode is shown.

- 3) Press [MENU] to select:

Record Lockout, Assemble, Crash or Insert Record mode.

- 4) INSERT ONLY - Press the desired Softkey to toggle *{Video}*, *{Audio1}*, *{Audio2}*, *{Audio3}*, or *{Audio4}* record on/off.

The **Softkeys** are located just below the display.

Follow the line graphic from the bottom of the display to the Softkey.

- 5) Press [ESC] to exit the MENU. The MENU indicator will turn off.

OR

Turn the Wheel for other setup options.

5. SIMULTANEOUS RECORD/PLAYBACK FUNCTIONS

a) SELECT SIMULTANEOUS RECORD/PLAYBACK MODE

- 1) Press [MENU] key.
- 2) Turn the wheel until the display shows “Simult. REC/PB:”
- 3) Press *[ON]* softkey to turn Simultaneous Record/Playback mode ON. In this mode, Recorder and Player channels of a DDR are treated as one VTR.

[VTR3] and [VTR4] keys are disabled in this mode.

Refer to Installation, Section 3, for connection information.

When this mode is OFF the controller behaves as a standard ST300 VTR controller.

- 4) Press [ESC] key to exit menu.

b) CREATE NEW CLIP

Prior to the start of the recording you must open a file on the DDR record channel. Each file (channel) must be given a unique name. Once the channels have been put into record, the clips need to be loaded on the corresponding play channel of the DDR.

- 1) Create a clip on the video server using local controls on the server unit. This opens a file ready for recording.

Do not start the record process at this time. Use the record function on the ST300 when you are ready to actually start recording.

- 2) Create a clip on each record channel of the video server.

c) START RECORD

NOTE: For some DDRs, create clip first.

- 1) Press [SHIFT] + [REC] on VTR1 to start recording on the Record channel connected to VTR3 connector on the rear of the ST300.
- 2) The Record LED turns ON.
- 3) Press [SHIFT] + [REC] on VTR 2 to start recording on the Record channel connected to VTR4 connector on the rear of the ST300.
- 4) The Record LED turns ON.

d) STOP RECORD

- 1) Press **[SHIFT]** + **[STOP]** on VTR1 to stop recording on the Record channel connected to VTR4 connector on the rear of the ST300.
- 2) The Record LED turns OFF.
- 3) Press **[SHIFT]** + **[STOP]** on VTR2 to stop recording on the Record channel connected to VTR4 connector on the rear of the ST300.
- 4) The Record LED turns OFF.

e) GO TO EE

Press **[EE]** key to go to Live video on the corresponding Playback Channel. The EE LED turns on.

f) GOTO LIVE

- 1) Press **[REC]** key.
- 2) The Player searches to the current Recorder time minus user-defined INPUT Video Delay (see SETUP MENU).
- 3) The Player starts playing.

Advanced Features . . .

6. TRANSFER CUELIST

a. TRANSMIT CUE LIST FUNCTION

The TRANSMIT CUE LIST function allows you to transmit your list of Cue Points to a PC, using the provided utility software on the PC, or to another ST300. Transfer to a PC requires OpSuite 3.0 software, which runs on a Windows-based computer. Contact DNF Controls for more information.

1) To Transmit Cue Points to another ST300

- a) Connect the VTR4 connector on the rear of the ST300 to the VTR4 connector of the receiving ST300 using an RS422 9-pin cable with TX and RX lines crossed. (A “turnaround” cable.)
- b) Press **[MENU]**.
- c) Scroll the Wheel until “Transmit CUE list? YES=Enter, Exit=ESC” is displayed.
- d) Press **[ENTER]** to start transmitting. The Display shows “Waiting to transmit” on the first line.
- e) When the Receiver is ready, transfer starts automatically. The Display now shows “Transmitting cuelist.”
- f) After the transfer is over, the display shows “Transfer is over” for one second and then shows “Waiting to transmit” again.
- g) Connect another ST300 to transmit the list again.

OR

Press **[ESC]** twice to exit the MENU mode.

2) To Transmit Cue Points to a PC

- a) Connect the VTR4 connector on the back of the ST300 to one of the COM ports on the PC using a RS422 to RS232 adapter.
- b) Repeat steps a) thru g) of “**To Transmit Cue Points to Another ST300,**” Section 6.a.1).

b. RECEIVE CUE LIST FUNCTION

The RECEIVE CUE LIST function allows you to receive a list of Cue Points from a PC or from another ST300. Transfer to a PC requires OpSuite 3.0 software, which runs on a Windows-based computer. Contact DNF Controls for more information.

1) To Receive Cue Points From Another ST300

- a) Connect the VTR4 connector on the back of the ST300 from the VTR4 connector of the transmitting ST300 using RS422 9-pin cable with TX and RX lines crossed.

(A “Turnaround” Cable)

- b) Press **[MENU]**.
- c) Scroll the Wheel until “Receive CUE List? YES=Enter, Exit=ESC” is displayed.
- d) Press **[ENTER]** to start receiving.
The Display shows “Waiting to receive” on the first line.
- e) When the Transmitter is ready, transfer starts automatically. The Display now shows “Receiving cuelist.”
- f) After the transfer is over the display shows “Done-Success! Press any key...”
- g) Press any key. The display shows “Receive cuelist?” message.
- h) Press **[ESC]** to exit the MENU mode.

2) To Receive Cue Points from the PC

- a) Connect the VTR4 connector on the back of the ST300 to one of the COM ports on the PC using RS422 to RS232 adapter.
- b) Repeat steps a) thru h) of “**To Receive Cue Points From Another ST300,**” Section 6.b.1).

Reference . . .

7. SETUP MENU

- ❑ Press [MENU]. The MENU indicator will turn on. Turn the Wheel to select item to change.
- ❑ Use the Softkeys to change the desired mode for that option. Turn the Wheel at anytime to select another item.
- ❑ Press [ESC] at anytime to exit **SETUP MENU**. The MENU indicator will turn off.

<u>MENU MODES</u>	<u>(Turning Wheel Clockwise)</u>
RECORD	<p>Press [MENU] to select the desired record mode: Lockout, Assemble, Crash (Full) or Insert.</p> <p><u>Only</u> in INSERT mode: Press the associated Softkey, located below the display, to toggle Video{V}, Audio1{A1}, Audio2{A2}, Audio3{A3}, Audio4{A4} on/off.</p>
MARK-Q	<p>Press Softkey to:</p> <p>Enable {ADVANCE} to next Cue Point, when [MARK] is pressed.</p> <p>OR</p> <p>Maintain {CURRENT} Cue Point when [MARK] is pressed.</p>
SIMULTANEOUS RECORD/ PLAYBACK	<p>Press Softkey to select:</p> <p>Simult. Rec/PB {OFF} ST300 works like the standard ST300 and does not use special functions</p> <p>Simult. Rec/PB {ON} ST300 uses Special Simultaneous Record/Playback functions. Connect ST300 to DDR using Simultaneous Record/Playback Mode ON Connection Diagram.</p>
WIND MODE	<p>Press Softkey to select:</p> <p>{HOLD} (Fast wind is maintained only while key is pressed.)</p> <p>OR</p> <p>{LATCH} (Fast wind is initiated and maintained with momentary key press.)</p> <p>Select fast wind speed (3.9 to 23.7) by pressing Softkey below {SPD}.</p>

<p>SLOMO</p>	<div style="border: 1px solid black; padding: 5px; margin-bottom: 10px;"> <p>SLOMO with: TBAR</p> <p>Wheel SpdRange Preset</p> </div> <p>ST300 display shows (Tbar version):</p> <div style="border: 1px solid black; padding: 5px; margin-bottom: 10px;"> <p>SLOMO with: WHEEL</p> <p>SpdRange Preset</p> </div> <p>ST300 display shows (Non T-Bar version):</p> <p>Press Softkey <i>{TBAR}</i> or <i>{WHEEL}</i> to toggle between T-BAR and WHEEL.</p> <p>The T-BAR has two speed ranges:</p> <p style="padding-left: 40px;">0 → +200 with a detent at +100 % play speed</p> <p style="text-align: center;">OR</p> <p style="padding-left: 40px;">0 → +100 with a detent at +100%</p> <p>For Wheel <u>only</u>:</p> <p>Press Softkey <i>{SPDRANGE}</i> to select SLOMO speed ranges:</p> <p>Press Softkey to select: <i>{0 → +200}</i> OR <i>{-100 → +200}</i>.</p> <p>Press Softkey <i>{BACK}</i> to return to SLOMO MENU.</p> <p>Press [ESC] to exit SETUP MENU</p> <p>OR turn the Wheel to select another item.</p> <p>For Wheel <u>only</u>:</p> <p>Press Softkey <i>{PRSET}</i> to select the SLOMO Preset Speed Mode.</p> <p style="padding-left: 40px;">Press Softkey <i>{UPDATE}</i>.</p> <p style="padding-left: 40px;">When exiting SLOMO mode, the last used speed is saved in the Preset Speed register.</p> <p style="padding-left: 40px;">Press Softkey <i>{STATIC}</i>.</p> <p style="padding-left: 40px;">The Preset Speed register is NOT updated when exiting SLOMO mode.</p> <p style="padding-left: 40px;">It is only changed by [SHIFT] + [SLOMO] (PRESET SLOMO).</p>
<p>TBAR AUTOENABLE</p>	<p>Press Softkey <i>{ON}</i> to enable slomo to be engaged by moving the TBAR.</p>

WHEEL AUTOENABLE	Press Softkey <i>{JOG}</i> or <i>{SHUTTLE}</i> to enable that function to be engaged by turning the Wheel.
VIDEO STANDARD	Press softkey to select <i>{NTSC}</i> , <i>{PAL}</i> or <i>{24P}</i> video standard, depending on the standard you are using.
GANG MODE	Press Softkey to select <i>{PERMANENT}</i> GANG (described in the FUNCTION Table) or <i>{TEMPORARY}</i> GANG. In TEMPORARY mode, press and hold the VTR key that you want to read status from, then press the VTR#s of those VTRs that you want to include in the gang. Release the keys. The LED on the monitored VTR blinks, all other VTRs in the gang stay on constantly. To break the temporary gang, press any VTR# key.
ST300 SETUP	<div style="border: 1px solid black; padding: 5px; margin-bottom: 10px;"> <p style="text-align: center;">ST300 SETUP</p> <p style="text-align: center;">Clear Cues SetDefault</p> </div> <p>Press Softkey beneath <i>{ClearCues}</i> to clear all Cue Points to 00:00:00:00.</p> <p>Press Softkey <i>{YES}</i> when asked “Are You Sure?” or <i>{NO}</i> to exit without clearing cues</p> <p>Press Softkey beneath <i>{SetDefault}</i> to set ST300 to default settings.</p> <p>Press Softkey <i>{YES}</i> when asked “Are You Sure?” or <i>{NO}</i> to exit without setting defaults.</p>
DISPLAY SOFTWARE VERSION	The version number for the currently installed software is displayed.
DROP FRAME	Press Softkey to select DROP FRAME <i>{ON}</i> or <i>{OFF}</i> . Used to preset the VTR’s Timecode Generator.
RECORD KEY	Press Softkey to select single button or 2-button record. RECORD = <i>{REC}</i> Only OR RECORD = <i>{REC + PLAY}</i>
FREEZE	Press Softkey <i>{YES}</i> to enable or <i>{NO}</i> to disable FREEZE at Record Outpoint. Changing mode automatically clears FREEZE point.
INPUT VIDEO DELAY	Input Video Delay specifies the time interval between video recorded on the Recorder parts being available for playback. This parameter is used in GOTO LIVE function. The default value is 5 seconds.
TRANSMIT CUELIST	Transmits Cuelist to another ST300 or to a PC. See section 6a.
RECEIVE CUELIST	Receives Cuelist from another ST300 or a PC. See section 6b.

8. FUNCTION TABLE

Function	Key Press	Description
EE On/Off	[EE]	Toggle EE mode on/off. Status indicator is on when EE is on.
EJECT TAPE	[SHIFT] + [REWIND]	Eject tape from VTR.
ENTER TIME	[ENTER TIME]	To manually enter timecode number into the currently displayed Cue Point, enter the desired timecode number using the numeric keypad. Press [ENTER] to save your entry OR [ESC] to exit without saving. To enter a GOTO location without altering the contents of the Cue Point, enter the desired timecode number using the numeric keypad. Press [GOTO] to search to the entered time. Press [ESC] to exit without searching.
S-RP GOTO EE	[EE]	Press [EE] to view live video.
S-RP START RECORD	[SHIFT] + [RECORD]	Press [SHIFT] + [RECORD] to start recording on selected record channel.
S-RP STOP RECORD	[SHIFT] + [STOP]	Press [SHIFT] + [STOP] to stop recording on the selected record channel.
FFWD	[FFWD]	Press and HOLD to FFWD. Release key to stop. Set WIND Speed in MENU.
FREEZE ENABLE	[FREEZE]	Toggles the Freeze on/off. When the light is ON, the Freeze is enabled. When the light is OFF, the freeze is disabled. NOTE: This is <u>NOT</u> a REC OUT freeze, it <u>IS</u> a user defined Freeze.
FREEZE	[SHIFT] + [FREEZE] (Active in SLO-MO only).	To enter or mark the Freeze time, press [SHIFT] + [FREEZE]. The display shows the current freeze time. You can enter the Freeze time using the numeric keypad or MARK the current time into the Freeze time by pressing [MARK].
FREEZE ON LAST GOOD VIDEO	Active in SLO-MO only.	In SLO-MO mode, STILL frame the VTR when the current timecode is within 6 frames of the last Record Out point (memorized automatically upon exiting Record mode). Enable, disable, or clear the FREEZE point from SETUP MENU. See FREEZE ENABLE.

Function	Key Press	Description
GOTO CUE or ENTERED TIME	[GOTO]	Search the VTR to the contents of the currently displayed Cue Point. If ENTER TIME is active (<i>LED is on</i>), search the VTR to the entered time. To enter a GOTO location without altering the contents of the Cue Point, press [ENTER TIME]. Enter the desired timecode number using the numeric keypad. Press [GOTO] to search to the entered time. Press [ESC] to exit without searching.
GANG	[SHIFT] + [VTR#1] OR [SHIFT] + [VTR#2] OR [SHIFT] + [VTR#3] OR [SHIFT] + [VTR#4]	NOTE : Gang mode = Permanent (See menu setup). Individually press the VTR keys to be included in the gang; the LED above the key will turn on. Press the VTR key again to remove from gang; the LED above the key will turn off. Press [ESC] to exit. The VTR LEDs that are on show the gang. The flashing LED shows which VTR is currently selected.
GO TO FREEZE POINT	[SHIFT] + [GOTO]	Search VTR to FREEZE point (last Record Out point).
JOG	[JOG]	Select JOG mode and enable the Wheel.
LAST CUE	[LAST CUE]	Step to the previous Cue Point Location.
MARK CUE POINT	[MARK]	Save the current time in the currently displayed Cue Point. Per SETUP MENU, the Cue Point Location will advance to the next Cue Point location or remain the same.
NEXT CUE	[NEXT CUE]	Step to the next Cue Point Location.
PREROLL	[PREROLL]	Preroll the VTR to the contents of the currently displayed Cue Point.
PREROLL VALUE	[SHIFT] + [PREROLL]	Enter desired Preroll Value. Press [ENTER] to save entry OR press [ESC] to exit without saving entry.
RECORD	[REC] or [REC] + [PLAY]	Places VTR in the Record mode selected by RECORD MODE in the SETUP MENU.
REVERSE PLAY	[REV]	For T-BAR ONLY – HOLD key to play video in reverse. RELEASE key to play forward.
REWIND	[RWD]	Press and HOLD to rewind. Release key to stop. Set WIND Speed in MENU.
SHUTTLE	[SHUTTLE]	Select SHUTTLE mode and enable the Wheel.

Function	Key Press	Description
SLOMO	[SLOMO]	<p>Press SLOMO to slo-mo the VTR. Turn the Wheel or move the T-Bar to change the play speed.</p> <p>Press SLOMO to STILL frame OR press any transport key to exit.</p>
SLO-MO SPEED PRESET	[SHIFT] + [SLOMO]	<p>For WHEEL ONLY - to preset the slo-mo speed. Turn the Wheel to select desired speed.</p> <p>Press [ESC] OR any transport key to exit.</p>
STOP	[STOP]	<p>Press once to STILL frame VTR.</p> <p>Press again to put VTR into STOP mode.</p>
TIME MODE SELECT	[TIME MODE]	<p>Press to toggle between Timecode (TC), VITC (VT) or Tape Timer (TM) display modes.</p>
TIME PRESET (Generator Preset)	[SHIFT] + [TIME MODE]	<p>Press to enter Time Preset.</p> <p>Press [ENTER] to load Time Generator with 00:00:00:00.</p> <p>OR enter the time desired via the numeric keypad and press [ENTER] to load that time.</p> <p>OR press [ESC] to exit without saving.</p>

9. SPECIFICATIONS

Power:	90 VAC to 265 VAC adapter supplied with IEC connector
Size:	(L" x W" x H") 12" x 6" x 1.5" (front) 3.0" (rear) (T-Bar unit is 12.6" long)
Weight:	4 lbs.
Rear Panel Connectors:	VTR1, VTR2, VTR3, VTR4 (All DB9F) GPI (DBF15F) Power (DB9M) Aux (DB9F) Reference Video (BNC)
Display:	Easy to read 2-line, back-lit LCD display (User adjustable contrast)
Jog/Shuttle Wheel	With mechanical detents
Optional "T"-bar	Slo-mo 0-200% of Play Speed

RS422 SERIAL CONNECTOR

9-Pin D-Type, Female (DB9F)

Pin #	1	Frame Ground	6	Receive Common
	2	Receive A ←	7	Receive B ←
	3	Transmit B →	8	Transmit A →
	4	Transmit Common	9	Frame Ground
	5	Spare		

POWER CONNECTOR

9-Pin D-Type, Male (DB9M)

Pin #	1	+5v DC	6	+5 VDC
	2	+5v DC	7	Ground
	3	Ground	8	Ground
	4	+12 VDC	9	Ground
	5	-12 VDC		

AUX PORT RS422 SERIAL CONNECTOR

9-Pin D-Type, Female

Pin #	1	Frame Ground	6	Transmit Common
	2	Receive A ←	7	Receive B ←
	3	Transmit B →	8	Transmit A →
	4	Receive Common	9	Frame Ground
	5	Spare		

GPI IN/OUT CONNECTOR

15-Pin D-Type, Female (DB15F)

Pin #	Description	Function	Pin #	Description	Function
1	GPI 1 Out	PLAY tally out	9	GPI 1 In	PLAY
2	GPI 2 Out	STILL/STOP tally out	10	GPI 2 In	STOP
3	GPI 3 Out	RECORD tally out	11	GPI 3 In	RECORD
4	GPI 4 Out	REWIND tally out	12	GPI 4 In	REWIND
5	GPI 5 Out	FFWD tally out	13	GPI 5 In	FFWD
6	GPI 6 Out	SLOMO tally out	14	GPI 6 In	SLOMO
7	GPI 7 Out		15	GPI 7 In	STILL
8	Ground				

10. KEY LAYOUT

ST300 KEY CONFIGURATION ST300-SSM (& -T)

NOTE- The "REV" key is only available on T-BAR(-T) models

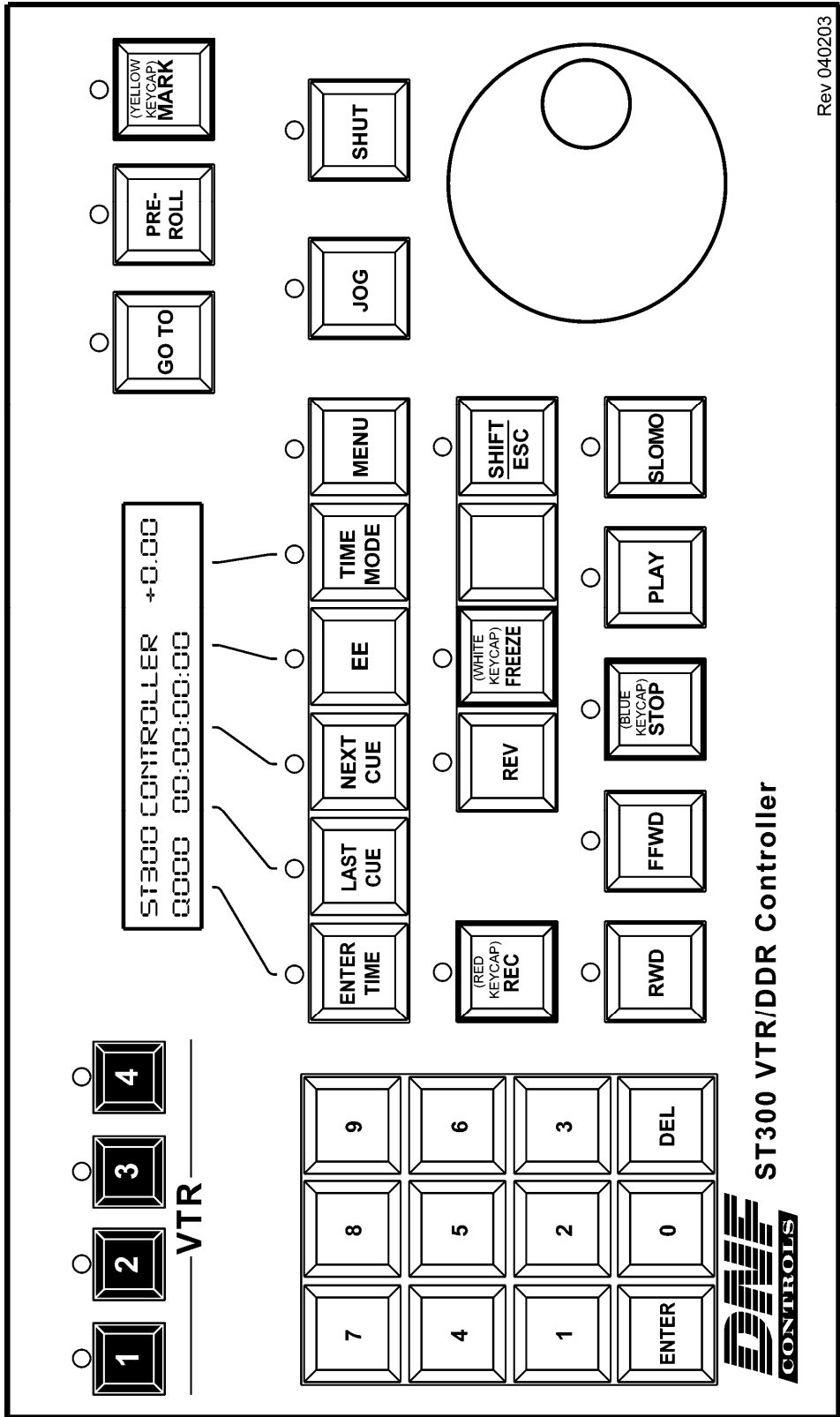

Rev 040203

ST300 VTR/DDR Controller



11. DNF CONTROLS LIMITED WARRANTY

DNF Controls warrants its product to be free from defects in material and workmanship for a period of one (1) year from the date of sale to the original purchaser from DNF Controls.

In order to enforce the rights under this warranty, the customer must first contact DNF's Customer Support Department to afford the opportunity of identifying and fixing the problem without sending the unit in for repair. If DNF's Customer Support Department cannot fix the problem, the customer will be issued a Returned Merchandise Authorization number (RMA). The customer will then ship the defective product prepaid to DNF Controls with the RMA number clearly indicated on the customer's shipping document. The merchandise is to be shipped to:

DNF Controls

12843 Foothill Blvd., Suite D

Sylmar, CA 91342

USA

Failure to obtain a proper RMA number prior to returning the product may result in the return not being accepted, or in a charge for the required repair.

DNF Controls, at its option, will repair or replace the defective unit. DNF Controls will return the unit prepaid to the customer. The method of shipment is at the discretion of DNF Controls, principally UPS Ground for shipments within the United States of America. Shipments to international customers will be sent via air. Should a customer require the product to be returned in a more expeditious manner, the return shipment will be billed to their freight account.

This warranty will be considered null and void if accident, misuse, abuse, improper line voltage, fire, water, lightning, or other acts of God damaged the product. All repair parts are to be supplied by DNF Controls, either directly or through its authorized dealer network. Similarly, any repair work not performed by either DNF Controls or its authorized dealer may void the warranty.

After the warranty period has expired, DNF Controls offers repair services at prices listed in the DNF Controls Price List. DNF Controls reserves the right to refuse repair of any unit outside the warranty period that is deemed non-repairable.

DNF Controls shall not be liable for direct, indirect, incidental, consequential or other types of damage resulting from the use of the product.

###